

DAYLE DESIGNS

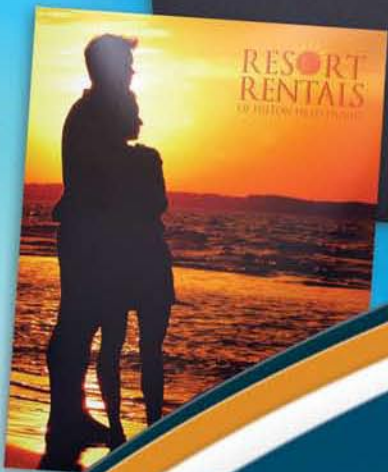

College of
St. JOSEPH
in Vermont



- presentation folders
- report & certificate covers
- key & card holders
- portfolios
- binders
- cd/dvd packaging
- totes & boxes
- photo holders
- pre-designed folders

asi/32050 • PPAI 111144 • UPIC: ADMORE

The Admore® Line

Design and Manufacture of Anything With Ink on It!

www.dayledesigns.biz • dayledesigns@comcast.net
8518 Kimmie St. SW • Olympia, Washington 98512

Phone/Fax **360-352-4051**

Dayle
Designs

ECONOMICAL FOUR COLOR PROCESS PRINTED FOLDERS • Ships in 3-5 days.



Affordable color. When you need it.
Are fast approaching deadlines or tight budgets putting a crimp in your style? Not any more. Present your message in beautiful, full color with our new Process Saver folder.

Product Information

Printing

Price includes printing in four color process only, in any location, on the front and back cover, plus pockets (one side of the sheet). Bleeds are allowed. Orders are run to standard color densities. **An overall gloss aqueous coating will be applied FREE.**

Artwork / Template

Price is based on customer supplied files (in acceptable programs with hard copy). Files **MUST** be submitted on our design template for Item 08-92-4CP. **Process graphics must be in CMYK and not RGB.** See page 47 for more information.

Production Time (3-5) Days

Production time is based on approved credit and acceptable file output. If a proof is required, production time begins **AFTER** proof approval.

3 working day schedule:

- Item must be ordered on-line and files must be uploaded at our website using our template.
- Files and order form must be received by **NOON EST** (Monday thru Friday).
- Orders are manufactured in Michigan only.

5 working day schedule:

- All artwork/orders sent via mail, email or not meeting the 3 day schedule criteria default to a 5 working day schedule.

Stock

12 pt. C1S Semi-gloss White stock **only.**

Quantities

1000 folders **only.**

Additional Information

Can be found on pages 47 and 48.

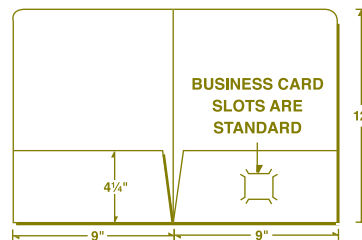

● 08-92-4CP

See price below.

Expect More. GET MORE.

Look for this icon throughout the catalog for helpful tips, marketing advice and important information.

1,000 PROCESS SAVER PRINTED FOLDERS WITH FREE GLOSS AQUEOUS COATING: \$1417 (R)



SUPER SAVERS

ECONOMICAL PRINTED FOLDERS • Ships in 5 days. Prints in one or two PMS colors. Low minimum quantity.



When you need folders fast...

Make an impression every time with the Super Saver line of printed folders.

These folders are an ideal solution when you need an affordable, high quality folder delivered quickly.

Great for trade shows, new product information, business presentations and so much more.

Artwork / Template

Price is based on customer supplied files (in acceptable programs with hard copy). Files **MUST** be submitted on our design template for Item 08-92-PMS. Submit art in spot color(s) and not RGB or CMYK. Send vector (.EPS art) with all type converted to outlines or 1200 dpi .TIF file. **No .JPG, .GIF or web images.** See page 47 for more information.

Stock

Base stocks are included in price. See table below for additional charges when using Group A, B or C stocks. Refer to stock selection groups on inside back cover.

Production Time

5 working days. Schedules can often be adjusted based on the specifics of your order. Tell us what you need.

Additional Information

Can be found on pages 47 and 48.

Expect More. GET MORE.

To make a simple one or two color printed design look like MORE, use a pastel colored stock or vertical textured stock instead of white.



Product Information

Printing PMS (limited graphics)

Price includes one or two PMS ink color(s), in any location, on the front and back cover, plus pockets. Line copy, logos, small screen areas and simple color traps are allowed. No heavy coverage or full bleeds. Order **MUST** specify a PMS number or a color match charge will be applied. **If necessary an overall gloss aqueous coating will be applied FREE.**

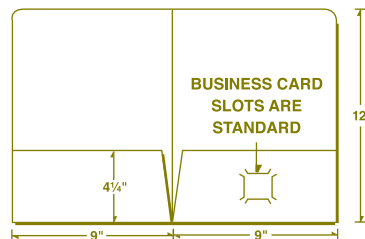

08-92-PMS

Price: See table below.

SUPER SAVER PRINTED FOLDER PRICES

08-92 PMS BASES	50	100	250	500	1000	1500	2000	2500	3000	5000	7500	10000
Print - One PMS color-limited	\$ 298	327	497	665	948	1225	1430	1627	1725	2418	3433	3932
Print - Two PMS colors-limited	\$ 433	462	635	820	1123	1422	1657	1890	2010	2747	3885	4487
OPTIONS/ADD TO BASE												
Group A Stocks	\$ 22	43	73	107	170	248	317	397	470	783	1175	1567
Group B Stocks	\$ 32	62	108	165	270	390	523	650	780	1300	1825	2267
Group C Stocks	\$ 43	77	138	217	433	650	833	1042	1250	2083	3125	3917

(R)

ECONOMICAL FOIL STAMPED FOLDERS • Ships in 5 days. Choice of 31 foil colors. Legal size available.



A touch of foil. A touch of class...

With Budget Cutter foil stamped folders, you can add style without extra cost or time. Perfect for handouts to clients, patients or employees. A great way to increase name retention for your business.

Artwork / Template

Price is based on customer supplied files (in acceptable programs with hard copy). Files **MUST** be submitted on our design template for Item 08-91 or Item 08-97. Submit one color art (no RGB or CMYK) in the size you want to appear on folder. Send vector (.EPS art) with all type converted to outlines. **No .JPG, .GIF or web images.** See page 47 for more information.

Production Time

5 working days. Schedules can often be adjusted based on the specifics of your order. Tell us what you need.

Blind Embossed Headings

Choose one **FREE** blind embossed heading to be positioned diagonally in the upper left corner of the front cover, allowing ample room in the lower half for your imprint.

Heading Choices:

- Important Papers
- Presentation
- Proof
- Proposal
- Services
- Tax Return
- Thank You
- Welcome

Additional Information

Can be found on pages 47 and 48.

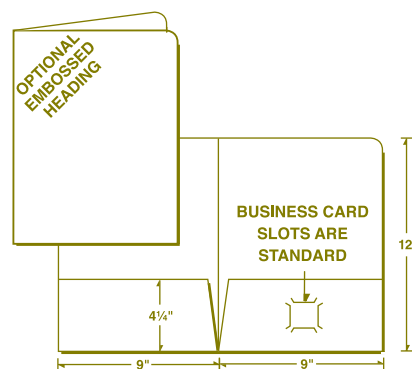

● 08-91 (shown above)

Price: See table below.

● 08-97 Legal Size

Measures 9 1/2" x 14 1/2" closed with two 3" pockets. Business card slots are standard as pictured above.

Price: See table below.

Product Information

Foil Stamping

Price includes a one color foil stamp imprint in one area, up to 15 square inches, in any location. If used with an embossed heading, the imprint must be positioned in the lower half of the front cover. Copy needs to remain 1/8" from any edge or fold. Use type that is 8 pt. or larger and avoid screens or copy with tight, intricate detail. See inside back cover for foil colors.

Stock

Base stocks are included in price. See table below for additional charges when using Group A, B or C stocks. Refer to stock selection groups on inside back cover.

BUDGET CUTTER FOIL STAMPED FOLDER PRICES

08-91 BASES	50	100	250	500	1000	1500	2000	2500	3000	5000	7500	10000
Foil Stamp – One area 15 sq. in.	\$ 278	308	433	540	865	1100	1332	1660	1753	2450	3453	4320
Plain Folders – No foil/emboss	\$ 235	275	390	497	742	1027	1215	1478	1570	2248	3207	3855

LEGAL SIZE BUDGET CUTTER FOIL STAMPED FOLDER PRICES

Foil Stamp – One area 15 sq. in.	\$ 388	435	563	747	1133	1502	1943	2328	2660	4183	5380	6538
----------------------------------	--------	-----	-----	-----	------	------	------	------	------	------	------	------

OPTIONS/ADD TO BASE

Group A Stocks	\$ 22	43	73	107	170	248	317	397	470	783	1175	1567
Group B Stocks	\$ 32	62	108	165	270	390	523	650	780	1300	1825	2267
Group C Stocks	\$ 43	77	138	217	433	650	833	1042	1250	2083	3125	3917

(R)

LARGE PRESENTATION FOLDERS



A folder, but so much MORE...

A folder not only presents your materials, it reinforces your name recognition and builds brand identity. Whether it's simple, elaborate or just plain fun – the image you want to project is there for your clients to see. An added plus, your documents are professionally organized and are kept on hand longer.



Lower prices on four color process and lamination!

Product Information

Artwork / Template

Price is based on customer supplied files (in acceptable programs with hard copy). Files **MUST** be submitted on the design template for the item ordered. See page 47 for more information.

Stock

Base stocks are included in price. See table below for additional charges when using Group A, B or C stocks. Refer to stock selection groups on inside back cover. UV coating is available on Semi-gloss White stock only.

Production Time

Top selling items 08-01 & 08-28:

Four color process or foil stamp: 5 working days.

Up to four PMS colors or embossing: 7 working days.

Other Items: 7-10 working days, except where noted.

Multiple processes require the most production time.

Schedules can often be adjusted based on the specifics of your order. Tell us what you need.

Pocket Options

A variety of card slots, brochure slits and other pocket options are available **FREE** of charge. See page 16.

Spine Attachments

Available in any of our Felt, Smooth, Vertical, Tweed, Hopsack, Linen, Cordwain and Oxford stocks. Indicate your stock and color choice when ordering. See table below for additional charge. Requires additional production time.



Additional Information

Can be found on pages 47 and 48.

Expect More. GET MORE.

Need inserts? They're on page 24. Stitched brochures? See page 25.

LARGE PRESENTATION FOLDER PRICES

BASES	250	500	1000	1500	2000	2500	3000	5000	7500	10000
Print – One PMS Color	\$ 562	742	1008	1332	1582	1875	2062	3112	3825	4335
Print – Two PMS Colors	\$ 700	897	1183	1528	1808	2138	2347	3440	4277	4890
Four Color Process	\$ 1267	1405	1577	1865	2123	2438	2637	3487	4360	5163
Foil Stamp or Emboss - 25 sq. in.	\$ 490	647	922	1157	1503	1803	2088	3173	3980	4990
OPTIONS/ADD TO BASE										
Additional PMS / Heavy Ink Coverage (per side)	\$ 158	177	200	225	258	300	325	375	517	633
Four Color Process (2nd side)	\$ 838	893	963	1180	1215	1233	1247	1383	1647	1925
Group A Stocks	\$ 73	107	170	248	317	397	470	783	1175	1567
Group B Stocks	\$ 108	165	270	390	523	650	780	1300	1825	2267
Group C Stocks	\$ 138	217	433	650	833	1042	1250	2083	3125	3917
Upcharge for 08-06, 08-08, 08-32, 08-55, 08-56, 08-61	\$ 87	152	250	373	485	580	657	1083	1577	1993
Upcharge for 08-57, 08-58, 08-59, 08-62	\$ 317	367	458	652	840	975	1153	1825	2525	3113
Aqueous Coating - Flood Gloss	\$ FREE	FREE	FREE	FREE	FREE	FREE	FREE	FREE	FREE	FREE
UV Coating - Flood Gloss	\$ 113	148	200	275	350	380	437	617	902	1043
Lamination - Plastic Gloss	\$ 122	185	313	442	570	698	827	1338	1980	2620
Lamination - Oversize Plastic Gloss	\$ 137	217	375	535	693	852	1012	1647	2442	3237
Spine Attachments	\$ 167	327	647	942	1255	1565	1873	3105	4613	6027

Please call for an estimate for: other stocks, matte lamination, UV printing, larger foil/emboss areas or combining ink with foil/emboss.

(R)

LARGE PRESENTATION FOLDERS

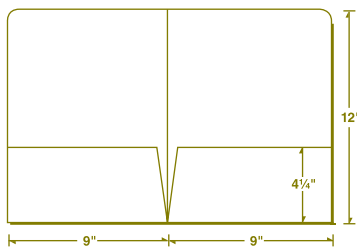

● **08-01 The Original**

Price: See table on page 4.

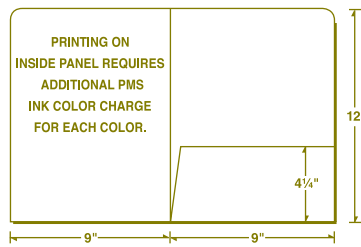

● **08-04, 08-05 One Pocket**

08-04 One right pocket (shown).

08-05 One left pocket.

Price: See table on page 4.

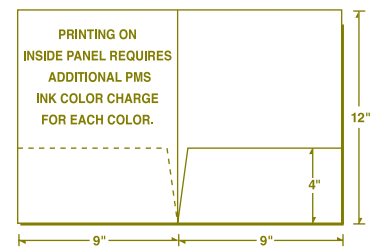

● **08-28, 08-29 Square Corners**

08-28 Two pockets (shown).

08-29 One right pocket only.

Price: See table on page 4.

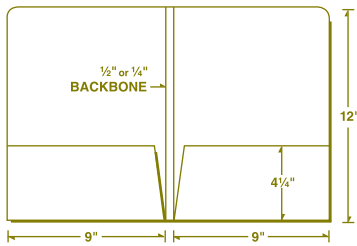

● **08-02, 08-03, 08-11 Backbone**

08-02 With 1/2" double score backbone.

08-03 With 1/2" triple score backbone.

08-11 With 1/4" double score backbone.

Price: See table on page 4.

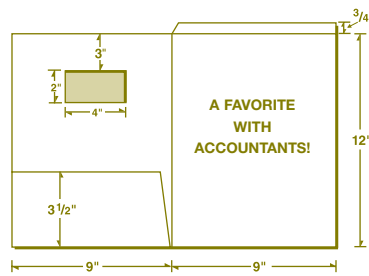

● **08-16 Fold Down Tab**

Papers staple to tab at top of back cover.

Window is optional.

Price: See table on page 4.

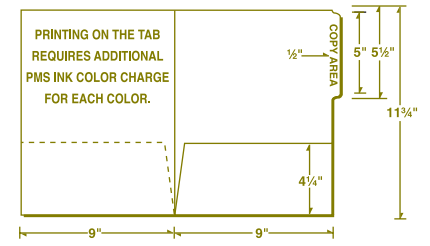

● **08-22, 08-21 File Tab**

08-22 Two pockets (shown).

08-21 One right pocket only.

Price: See table on page 4.

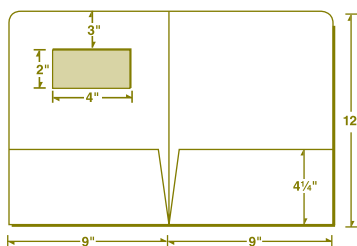

● **08-09 With Window**

Price: See table on page 4.

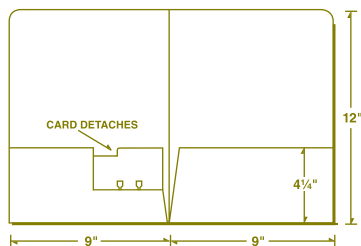

● **08-01 RFC**

Price: See table on page 4.

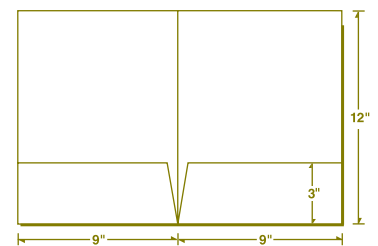

● **08-10 With 3" Pockets**

Price: See table on page 4.

LARGE PRESENTATION FOLDERS

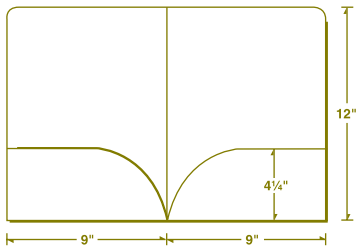

● **08-63 Curved Pockets**
Price: See table on page 4.

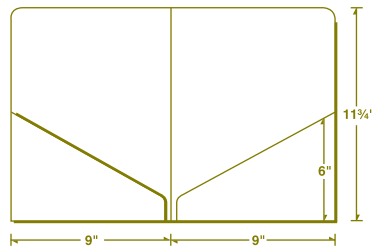

● **08-61 Diagonal Pockets**
Price: Base price *plus* the item upcharge shown in table on page 4.
Apply oversize lamination charge if laminating.

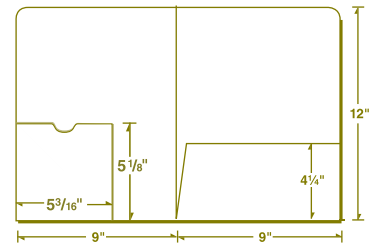

● **08-62 Folder with 5" CD Sleeve & One Right Pocket**
Price: Base price *plus* the item upcharge shown in table on page 4.
Production Time: 15 working days.

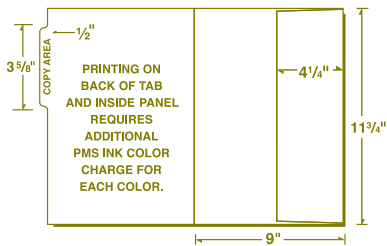

● **08-50 File Tab Vertical Pocket**
Price: See table on page 4.

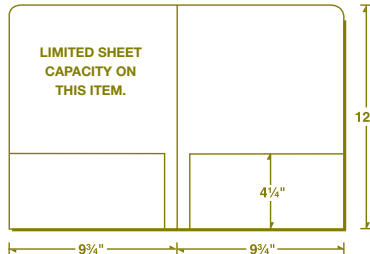

● **08-27 Pockets Glued on Both Sides**
Price: Call for an estimate.
Production Time: 15 working days.

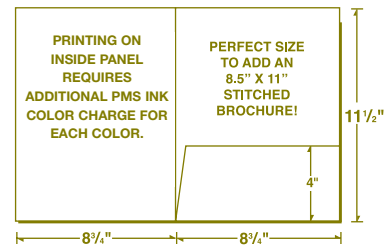

● **08-60 One Right Pocket Folder**
Price: See table on page 4.

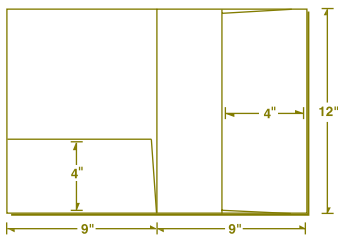

● **08-57, 08-59 Regular & Vertical**
08-57 Vertical pocket on the right (shown).
08-59 Vertical pocket on the left.
Price: Base price *plus* the item upcharge shown in table on page 4.

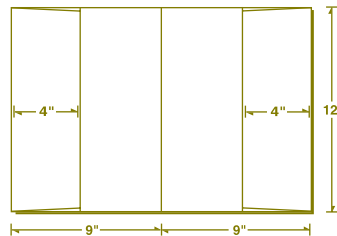

● **08-58 Two Vertical Pockets**
Price: Base price *plus* the item upcharge shown in table on page 4.

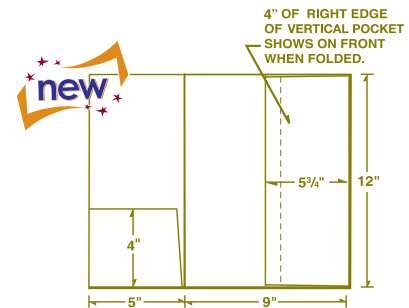

● **08-32 Small & Vertical Pockets**
Price: Base price *plus* the item upcharge shown in table on page 4.

LARGE PRESENTATION FOLDERS

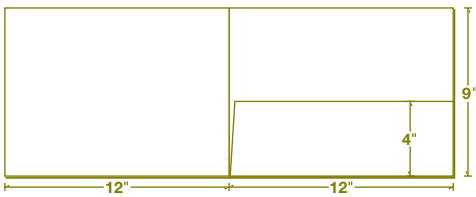

● 08-06 One Pocket Landscape

Price: Base price *plus* the item upcharge shown in table on page 4.
Apply oversize lamination charge if laminating.

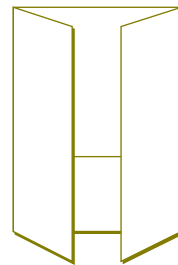

● 08-07 One Pocket Gatefold

Price: See table on page 4.
Lamination not recommended on this item.

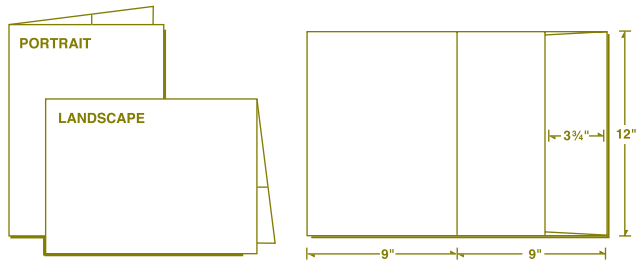
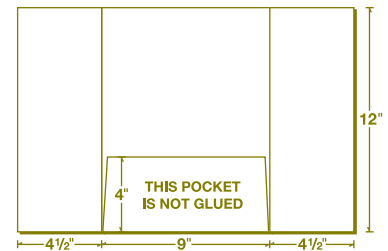

● 08-51 Portrait or Landscape Pocket

Specify portrait or landscape format when ordering.
Corner card slots are not available.
Price: See table on page 4.

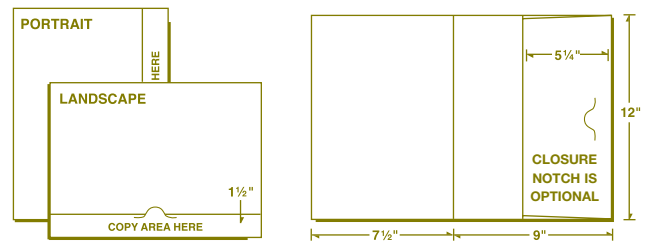

● 08-52 Oversized Portrait or Landscape Pocket

Specify portrait or landscape format when ordering.
Corner card slots are not available.
Price: See table on page 4.

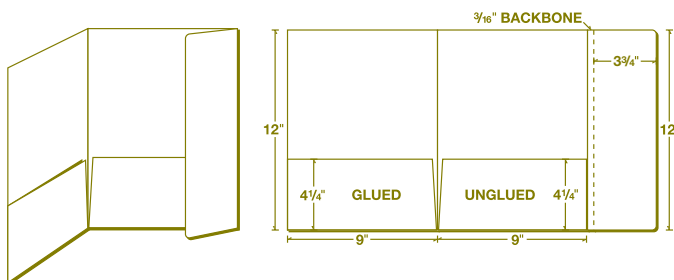

● 08-08 Info Flap

Standard with flap folding to inside.
Price: Base price *plus* the item upcharge shown in table on page 4.
Apply oversize lamination charge if laminating.

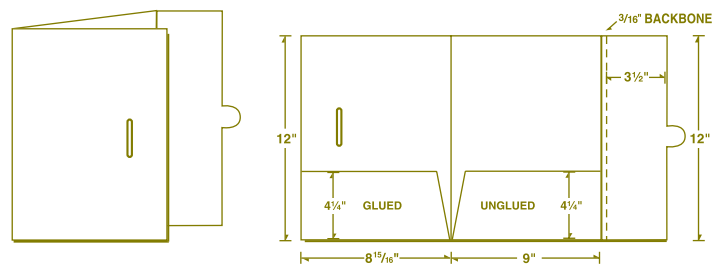

● 08-55, 08-56 Folder with Tuck Tab

08-55 Flap on the right, right pocket unglued (shown).
08-56 Flap on the left, left pocket unglued.
Price: Base price *plus* the item upcharge shown in table on page 4.
Apply oversize lamination charge if laminating.

LEGAL SIZE PRESENTATION FOLDERS



Legally speaking...

We've got you covered. Banking, finance, real estate, mortgage, credit union, legal, title or any other oversized documents you may have, rest easy...they're in a safe place. Tucked into one of our folders!

Need more legal capacity?

Several legal size folders with capacity pockets are found on page 13. Our

Conformer® Expansion Item 08-45 is a favorite!



Lower prices on four color process and lamination!

Product Information

Artwork / Template

Price is based on customer supplied files (in acceptable programs with hard copy). Files **MUST** be submitted on the design template for the item ordered. See page 47 for more information.

Stock

Base stocks are included in price. See table below for additional charges when using Group A, B or C stocks. Refer to stock selection groups on inside back cover. UV coating is available on Semi-gloss White stock only.

Production Time

7 - 10 working days. Multiple processes require the most production time. Schedules can often be adjusted based on the specifics of your order. Tell us what you need.

Additional Information

Can be found on pages 47 and 48.

Pocket Options

A variety of card slots, brochure slits and other pocket options are available **FREE** of charge. See page 16.

Expect More. **GET MORE.**

On a legal size budget? Check out our economy foil stamp "Legal Size Budget Cutter", **Item 08-97** on page 3.

Or, consider a legal sized portfolio instead of a folder. Check out our economy pre-designed portfolio on page 38.



LEGAL SIZE FOLDER PRICES

BASES	250	500	1000	1500	2000	2500	3000	5000	7500	10000
Print - One PMS Color	\$ 648	893	1258	1705	2067	2455	2718	4195	5402	6328
Print - Two PMS Colors	\$ 787	1048	1433	1902	2293	2718	3003	4523	5853	6883
Four Color Process	\$ 1353	1557	1827	2238	2608	3018	3293	4570	5937	7157
Foil Stamp or Emboss - 25 sq. in.	\$ 577	798	1172	1530	1988	2383	2745	4257	5557	6983
OPTIONS / ADD TO BASE										
Additional PMS / Heavy Ink Coverage (per side)	\$ 158	177	200	225	258	300	325	375	517	633
Four Color Process (2nd side)	\$ 838	893	963	1180	1215	1233	1247	1383	1647	1925
Group A Stocks	\$ 73	107	170	248	317	397	470	783	1175	1567
Group B Stocks	\$ 108	165	270	390	523	650	780	1300	1825	2267
Group C Stocks	\$ 138	217	433	650	833	1042	1250	2083	3125	3917
Item Upcharge for 29-83, 08-46, 08-48	\$ 75	90	163	242	307	342	360	392	421	450
Aqueous Coating - Flood Gloss	\$ FREE	FREE	FREE	FREE	FREE	FREE	FREE	FREE	FREE	FREE
UV Coating - Flood Gloss	\$ 113	148	200	275	350	380	437	617	902	1043
Lamination - Oversize Plastic Gloss	\$ 137	217	375	535	693	852	1012	1647	2442	3237

Please call for an estimate for: other stocks, matte lamination, UV printing, larger foil/emboss areas or combining ink with foil/emboss.

(R)

LEGAL SIZE PRESENTATION FOLDERS

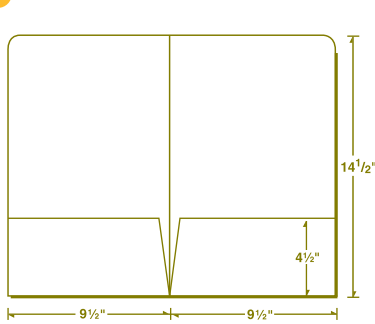

● **08-13 Legal Size with 4 1/2" Pockets**

Price: See table on page 8.

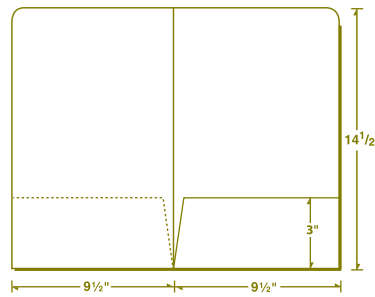

● **08-17, 08-44 Legal Size with 3" Pocket(s)**

08-17 Two pockets (shown).

08-44 One right pocket.

Price: See table on page 8.

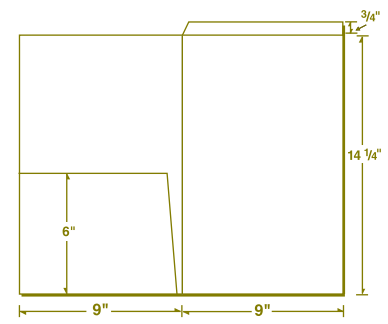

● **08-20 Legal Size with Fold Down Tab**

Papers staple to tab at top of back cover.

Price: See table on page 8.

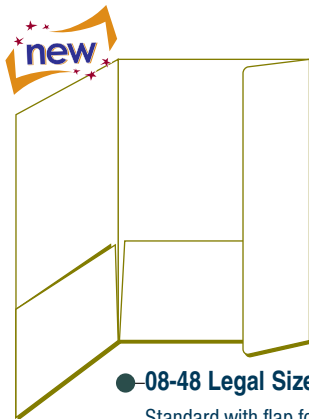

● **08-48 Legal Size Info Flap**

Standard with flap folding to inside.

Price: Base price *plus* the item upcharge shown in table on page 8.

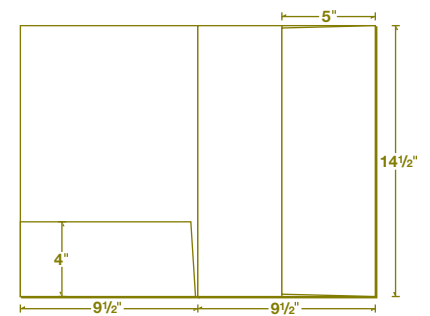
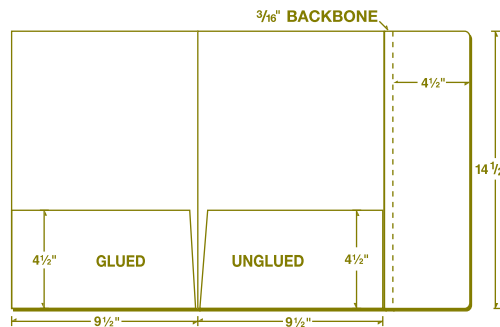

● **08-46 Legal Size Vertical Pocket**

Price: Base price *plus* the item upcharge shown in table on page 8.

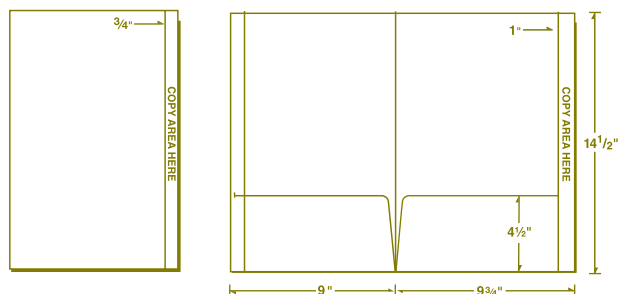

● **29-83 Legal Size Reinforced Edge Tab**

Price: Base price *plus* the item upcharge shown in table on page 8.

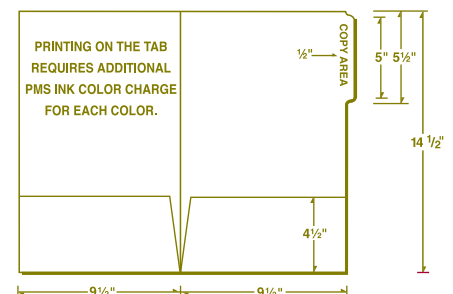

● **08-47 Legal Size File Tab**

Price: See table on page 8.

REINFORCED EDGE FOLDERS



Bring in the reinforcements....

For those presentations that require a little more strength, our reinforced side edges will get the job done.

A full one inch of extra stock is folded over and glued down at each side edge.

This provides extra durability when opening and closing the folder.

Need a reinforced top edge?

They are available on many of the designs shown. Call for details.

Product Information

Artwork / Template

Price is based on customer supplied files (in acceptable programs with hard copy). Files **MUST** be submitted on the design template for the item ordered. See page 47 for more information.

Stock

Base stocks are included in price. See table below for additional charges when using Group A, B or C stocks. Refer to stock selection groups on inside back cover. UV coating is available on Semi-gloss White stock only.

Production Time

7 - 10 working days. Multiple processes require the most production time. Schedules can often be adjusted based on the specifics of your order. Tell us what you need.

Additional Information

Can be found on pages 47 and 48.

Pocket Options

A variety of card slots, brochure slits and other pocket options are available **FREE** of charge. See page 16.

Spine Attachments

Available in any of our Felt, Smooth, Vertical, Tweed, Hopsack, Linen, Cordwain and Oxford stocks. Indicate your stock and color choice when ordering. See table below for additional charge. Requires additional production time.



Expect More. GET MORE.

Want your folder to be even MORE durable? Add plastic film lamination to your folder.



Lower prices on four color process and lamination!

REINFORCED EDGE FOLDER PRICES

BASES	250	500	1000	1500	2000	2500	3000	5000	7500	10000
Print - One PMS Color	\$ 627	815	1155	1552	1857	2197	2420	3543	4293	4840
Print - Two PMS Colors	\$ 765	970	1330	1748	2083	2460	2705	3872	4745	5395
Four Color Process	\$ 1332	1478	1723	2085	2398	2760	2995	3918	4828	5668
Foil Stamp or Emboss - 25 sq. in.	\$ 555	720	1068	1377	1778	2125	2447	3605	4448	5495
OPTIONS/ADD TO BASE										
Additional PMS/ Heavy Ink Coverage (per side)	\$ 158	177	200	225	258	300	325	375	517	633
Four Color Process (2nd side)	\$ 838	893	963	1180	1215	1233	1247	1383	1647	1925
Group A Stocks	\$ 73	107	170	248	317	397	470	783	1175	1567
Group B Stocks	\$ 108	165	270	390	523	650	780	1300	1825	2267
Group C Stocks	\$ 138	217	433	650	833	1042	1250	2083	3125	3917
Aqueous Coating - Flood Gloss	\$ FREE	FREE	FREE	FREE	FREE	FREE	FREE	FREE	FREE	FREE
UV Coating - Flood Gloss	\$ 113	148	200	275	350	380	437	617	902	1043
Lamination - Plastic Gloss	\$ 122	185	313	442	570	698	827	1338	1980	2620
Lamination - Oversize Plastic Gloss	\$ 137	217	375	535	693	852	1012	1647	2442	3237
Spine Attachments	\$ 167	327	647	942	1255	1565	1873	3105	4613	6027

Please call for an estimate for: other stocks, matte lamination, UV printing, larger foil/emboss areas or combining ink with foil/emboss.

(R)



Please note all Reinforced Edge Folders have new item numbers.

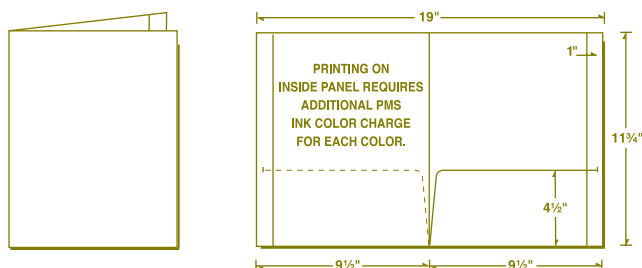

● **29-71, 29-74 Reinforced Edges**

29-71 Two pockets (shown).

29-74 One right pocket.

Price: See table on page 10.

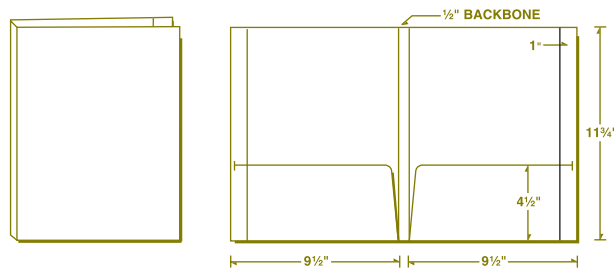

● **29-72 Reinforced Edges with 1/2" Backbone**

Price: See table on page 10.

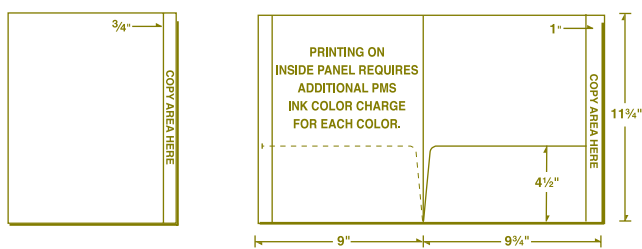

● **29-75, 29-77 Reinforced Edges File Tab**

29-75 Two pockets (shown).

29-77 One right pocket.

Price: See table on page 10.

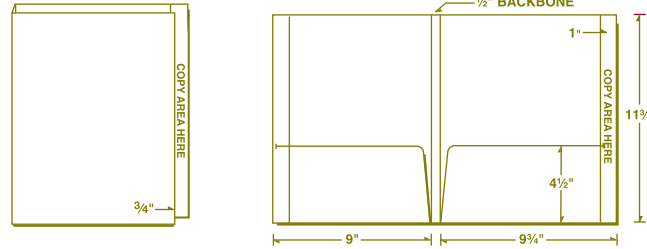

● **29-76 Reinforced Edges File Tab with 1/2" Backbone**

Price: See table on page 10.

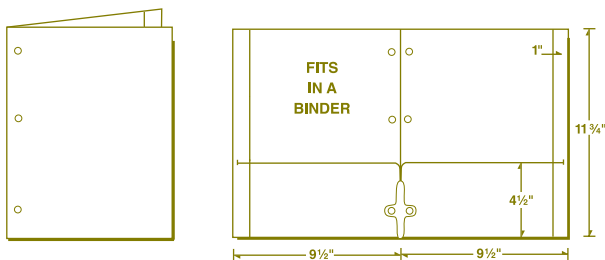

● **29-78 Reinforced Edges School Folder**

Comes 3-hole punched to fit in a ring binder!

Price: See table on page 10.

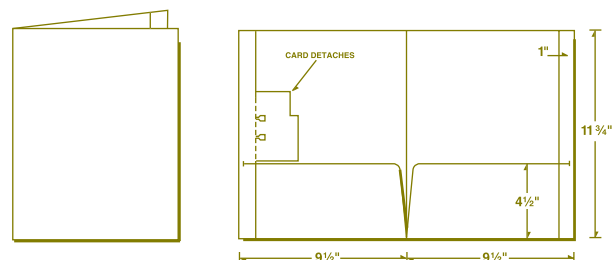

● **29-81 Reinforced Edges with Detachable Rotary File Card**

Price: See table on page 10.

Apply oversize lamination upcharge if laminating.

CAPACITY PRESENTATION FOLDERS



Pockets with Holding Power!

For those moments when you have **MORE** to say than a regular pocket will hold.

Traditional box pockets for capacity you know you need.

Zippered pockets that expand if and when you need them.

Conformer® Expansion Products with the latest patented technology. They expand to fit their contents while laying flat and saving on shipping.



Lower prices on four color process and lamination!

Product Information

Artwork / Template

Price is based on customer supplied files (in acceptable programs with hard copy). Files **MUST** be submitted on the design template for the item ordered. See page 47 for more information.

Stock

Base stocks are included in price. See table below for additional charges when using Group A, B or C stocks. Refer to stock selection groups on inside back cover. UV coating is available on Semi-gloss White stock only.

Production Time

7 - 10 working days. Multiple processes require the most production time. Schedules can often be adjusted based on the specifics of your order. Tell us what you need.

Pocket Options

A variety of card slots, brochure slits and other pocket options are available **FREE** of charge. See page 16.

Additional Information

Can be found on pages 47 and 48.

Conformer® Expansion Products

A U.S. patent number is required to appear on all Conformer® Expansion Folders. We will automatically add this copy in small type to the back cover of **Item 08-65** and **Item 08-45**.

Expect More. GET MORE.

Need the "perfect expansion pair"?

See Conformer® Expansion products

Item 08-65 folder on page 13 and portfolio **Items 16-04 & 16-05** on page 38.



CAPACITY PRESENTATION FOLDER PRICES

BASES	250	500	1000	1500	2000	2500	3000	5000	7500	10000
Print - One PMS Color	\$ 627	815	1155	1552	1857	2197	2420	3543	4293	4840
Print - Two PMS Colors	\$ 765	970	1330	1748	2083	2460	2705	3872	4745	5395
Four Color Process	\$ 1332	1478	1723	2085	2398	2760	2995	3918	4828	5668
Foil Stamp or Emboss - 25 sq. in.	\$ 555	720	1068	1377	1778	2125	2447	3605	4448	5495
OPTIONS/ADD TO BASE										
Additional PMS/Heavy Ink Coverage (per side)	\$ 158	177	200	225	258	300	325	375	517	633
Four Color Process (2nd side)	\$ 838	893	963	1180	1215	1233	1247	1383	1647	1925
Group A Stocks	\$ 73	107	170	248	317	397	470	783	1175	1567
Group B Stocks	\$ 108	165	270	390	523	650	780	1300	1825	2267
Group C Stocks	\$ 138	217	433	650	833	1042	1250	2083	3125	3917
15 pt. C1S Semi-gloss White Stock	\$ 73	107	170	248	317	397	470	783	1175	1567
Item Upcharge for 08-45, 28-13	\$ 93	163	265	388	508	603	717	1158	1563	2022
Item Upcharge for 08-12, 08-53	\$ 110	210	300	348	458	567	667	1058	1252	1512
Aqueous Coating - Flood Gloss	\$ FREE	FREE	FREE	FREE	FREE	FREE	FREE	FREE	FREE	FREE
UV Coating - Flood Gloss	\$ 113	148	200	275	350	380	437	617	902	1043
Lamination - Plastic Gloss	\$ 122	185	313	442	570	698	827	1338	1980	2620
Lamination - Oversize Plastic Gloss	\$ 137	217	375	535	693	852	1012	1647	2442	3237

Please call for an estimate for: other stocks, matte lamination, UV printing, larger foil/emboss areas or combining ink with foil/emboss.

(R)

CAPACITY PRESENTATION FOLDERS

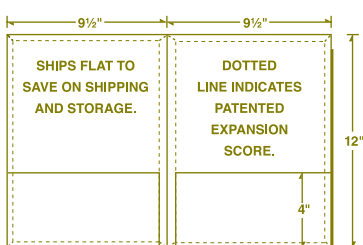

● 08-65 Conformer® Expansion Folder

Unique design expands to hold $\frac{3}{8}$ " per pocket.
Price: See table on page 12.

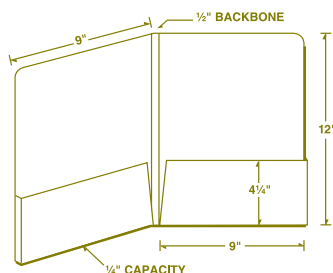

● 08-12, 08-53 Capacity Box Pockets

08-12 Two capacity pockets (shown).
08-53 Regular left pocket; capacity right pocket, square corners.
Price: Base price *plus* the item upcharge shown in table on page 12.

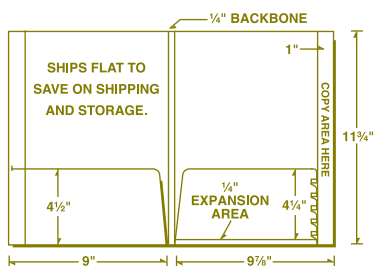

● 28-86 Reinforced Edges File Tab with Expandable Pocket

Regular left pocket with expandable right pocket.
Price: See table on page 12.

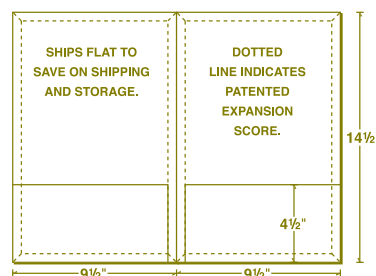

● 08-45 Conformer® Expansion Legal Size

Unique design expands to hold $\frac{3}{8}$ " per pocket.
Price: Base price *plus* the item upcharge shown in table on page 12.
Apply oversize lamination charge if laminating.

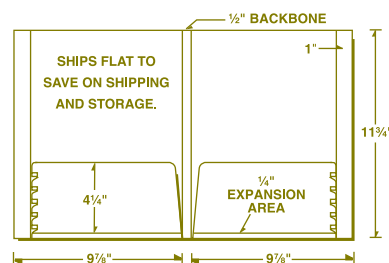

● 28-72 Reinforced Edges with Two Expandable Pockets

Price: See table on page 12.
Apply oversize lamination charge if laminating.

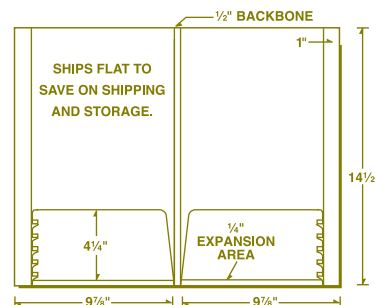

● 28-13 Legal Size with Two Expandable Pockets

Price: Base price *plus* the item upcharge shown in table on page 12.
Apply oversize lamination charge if laminating.

THREE-PANEL PRESENTATION FOLDERS



Easy as one, two, three panels...

When you need room to spread your message out and strategically locate sections of material, you need a three panel folder.

Fill the front and back sides of all panels with information and pictures and you have a presentation folder billboard. Add card slots or slits for your brochures and you have a complete package. A favorite among home builders, financial planners and medical providers!



Lower prices on lamination!

Product Information

Artwork / Template

Price is based on customer supplied files (in acceptable programs with hard copy). Files **MUST** be submitted on the design template for the item ordered. See page 47 for more information.

Stock

Base stocks are included in price. See table below for additional charges when using Group A, B or C stocks. Refer to stock selection groups on inside back cover. UV coating is available on Semi-gloss White stock only.

Production Time

10 working days. Schedules can often be adjusted based on the specifics of your order. Tell us what you need.

Additional Information

Can be found on pages 47 and 48.

Pocket Options

A variety of card slots, brochure slits and other pocket options are available **FREE** of charge. See page 16.

Spine Attachments

Available in any of our Felt, Smooth, Vertical, Tweed, Hopsack, Linen, Cordwain and Oxford stocks. Indicate your stock and color choice when ordering. See table below for additional charge. Requires additional production time.



Expect More. GET MORE.

Need a smaller 3-panel folder? See page 21.
Need inserts? They're on page 24.
Stitched brochures? See page 25.

THREE-PANEL PRESENTATION FOLDER PRICES

BASES	250	500	1000	1500	2000	2500	3000	5000	7500	10000
Print - One PMS Color	\$ 870	1035	1395	1888	2257	2700	2838	3887	5100	6363
Print - Two PMS Colors	\$ 1050	1237	1623	2143	2552	3042	3208	4313	5687	7085
Four Color Process	\$ 1445	1603	1937	2442	2840	3128	3322	4452	5960	7468
Foil Stamp or Emboss - 25 sq. in.	\$ 658	870	1215	1605	2083	2502	2895	4515	5667	6683
OPTIONS/ADD TO BASE										
Additional PMS/Heavy Ink Coverage (per side)	\$ 158	177	200	225	258	300	325	375	517	633
Four Color Process (2nd Side)	\$ 838	893	963	1180	1215	1233	1247	1383	1647	1925
Group A Stocks	\$ 98	132	177	267	353	443	530	883	1327	1768
Group B Stocks	\$ 213	353	530	797	1062	1327	1592	2652	3980	5305
Group C Stocks	\$ 420	525	808	1200	1567	1958	2300	3833	5750	7667
Aqueous Coating - Flood Gloss	\$ FREE	FREE	FREE	FREE	FREE	FREE	FREE	FREE	FREE	FREE
UV Coating - Flood Gloss	\$ 147	193	260	358	455	493	568	802	1172	1357
Lamination - Oversize Plastic Gloss	\$ 185	283	480	675	872	1068	1263	2048	3028	4010
Spine Attachments	\$ 183	343	663	958	1272	1582	1890	3122	4630	6043

Please call for an estimate for: other stocks, matte lamination, UV printing, larger foil/emboss areas or combining ink with foil/emboss.

(R)

THREE-PANEL PRESENTATION FOLDERS

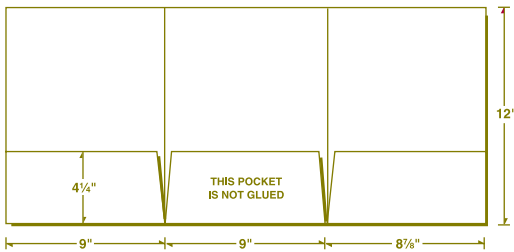

● **38-01 Three Panels, Three Pockets**

Price: See table on page 14.

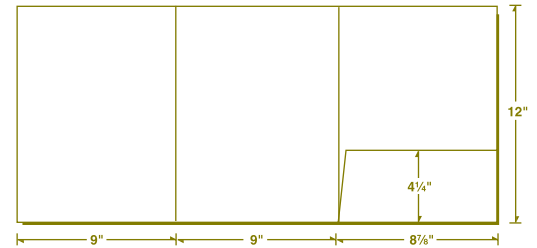

● **38-04, 38-03 Three Panels, One Pocket**

38-04 One glued right pocket (shown).

38-03 One unglued center pocket.

Price: See table on page 14.

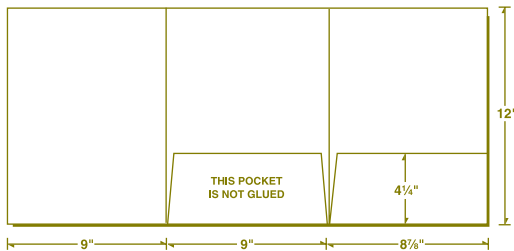

● **38-06, 38-07 Three Panels, Two Pockets**

38-06 Right and center pocket (shown).

38-07 Left and center pocket.

Price: See table on page 14.

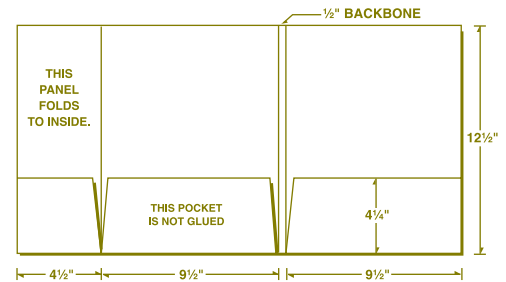

● **38-32, 38-33 Three Panels, Small Pocket**

38-32 Small pocket on left (shown).

38-33 Small pocket on right.

Price: See table on page 14.

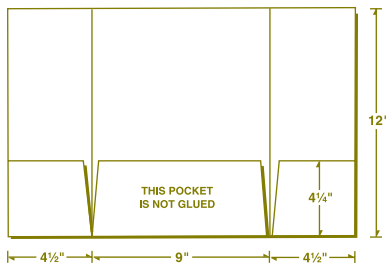

● **38-34 Three Panels, Three Pockets, Gatefold**

Price: See table on page 14.

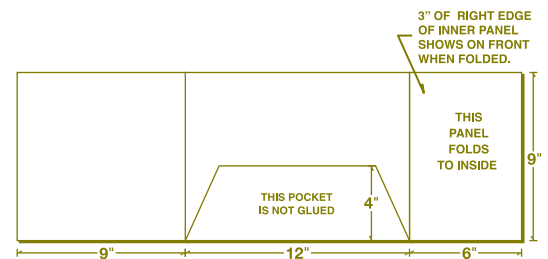

● **38-51 Three Panels, One Pocket Landscape**

Price: See table on page 14.



What works best for you?

We've made it easy to choose just the right pocket option to make your folder even **MORE** functional.

Standard options shown are FREE.

Custom pocket options are available for an additional charge. Not all items have card slot options.

Need MORE card slot options?

Many of our items are available with card slots in special positions unique to the item. See our **DESIGN TEMPLATES** for all the standard slit / slots available for each individual item for no additional charge.

CORNER
STYLE



H-1



H-2



H-3



V-1

NOTCHED
STYLE



V-4



H-4



C-1

● Business Card Slots

Two styles are available: **corner** and **notched**.
Holds a standard 2" x 3 1/2" business card.

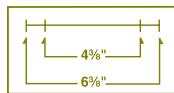

● Brochure Slits

Two lengths are available: 4 3/8" and 6 3/8".
Slits are positioned 7/8" down on 4 1/4" pockets,
1" down on 4 1/2" pockets and 3/4" down on 4" pockets.



● CD Slits

5 1/4" slit is available. Slit is positioned 7/8" down on 4 1/4" pockets,
1" down on 4 1/2" pockets and 3/4" down on 4" pockets.

TWO-PIECE REPORT COVERS

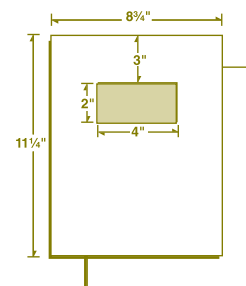

- **75-01 Two-Piece Cover**
75-09 With Window (shown)

Price: See table below.

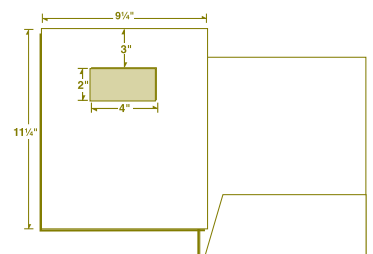

- **75-04 Two-Piece Cover with Pocket**
75-49 With Window (shown)

Price: Base price *plus* the item upcharge shown in table below.

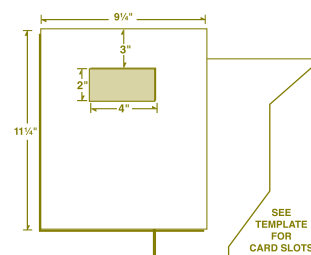

- **75-24 Two-Piece with Vertical Pocket**
75-29 With Window (shown)

Price: Base price *plus* the item upcharge shown in table below.

In a bind?

Our two-piece report covers will get you out of it. Insert your 8 1/2" x 11" pages between these beautiful covers and you will instantly make a professional statement. Great for binding a large volume of papers or just stapling a few pages together.

Product Information

Printing PMS (limited graphics)

Price includes limited coverage of 30% or less of the surface area of front cover only, in one or two PMS ink color(s). No bleeds; copy must remain 3/8" from edges. If using heavier ink coverage or bleeds, add heavy ink coverage charge found in table below. Orders **MUST** specify a PMS number or a color match charge will be applied.

BACK COVER: For back cover printing, add an additional ink color charge for each color used.

Artwork / Template

Price is based on customer supplied files (in acceptable programs with hard copy). Files **MUST** be submitted on the design template for the item ordered.

Foil or Emboss: Submit one color art (no RGB or CMYK) in the size you want to appear on cover. Send vector (.EPS art) with all type converted to outlines. **No .JPG, .GIF or web images.** See page 47 for more information.

Stock

Base stocks are included in price. See table below for additional charges when using Group A, B or C stocks. Refer to stock selection groups on inside back cover.

Production Time

7 working days. Schedules can be adjusted based on the specifics of your order. Tell us what you need.

Additional Information

Can be found on pages 47 and 48.

Blind Embossed Headings

FREE on foil stamped or embossed orders. Your choice of one heading (see list on page 3) positioned diagonally in the upper left corner of the front cover.

Plastic Binding Strips

These 11 1/4" long strips slide over cover edges, creating a binding (holds 1/8" capacity). Available in white, black or brown for the additional charge shown in table below. Specify color when ordering.

TWO-PIECE REPORT COVER PRICES

BASES	250	500	1000	1500	2000	2500	3000	5000	7500	10000
Print – One PMS Color - Limited	\$ 252	320	408	570	693	843	988	1417	2025	2445
Print – Two PMS Colors - Limited	\$ 390	475	583	767	920	1107	1273	1745	2477	3000
Four Color Process	\$ 988	1147	1377	1545	1753	1955	2207	2962	3568	4455
Foil Stamp or Emboss - 15 sq. in.	\$ 367	460	602	775	957	1128	1313	2020	2695	3165
OPTIONS / ADD TO BASE										
Additional PMS Ink color (per side) - Limited	\$ 158	177	200	225	258	300	325	375	517	633
Heavy Ink Coverage (per side)	\$ 158	177	200	225	258	300	325	375	517	633
Group A Stocks	\$ 53	77	123	178	228	285	338	560	835	1112
Group B Stocks	\$ 75	115	203	293	390	488	585	975	1368	1700
Group C Stocks	\$ 97	152	303	455	592	730	875	1458	2188	2742
Item Upcharge for 75-04, 75-49, 75-24, 75-29	\$ 322	347	468	640	788	953	1090	1722	2208	2533
Plastic Binding Strips	\$ 47	92	183	275	367	458	550	917	1375	1833
Aqueous Coating - Flood Gloss	\$ FREE	FREE	FREE	FREE	FREE	FREE	FREE	FREE	FREE	FREE

Please call for an estimate for: other stocks, laminating, UV coating, UV printing, larger foil/emboss areas or combining ink with foil/emboss.

(R)

ONE-PIECE REPORT COVERS

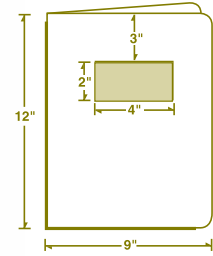

● 09-01 Without Window
 09-09 With Window (shown)
 Price: See table below.

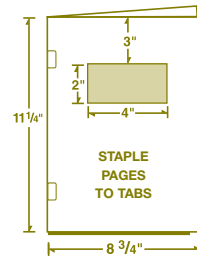

● 09-15 Cover with Tabs
 09-19 With Window (shown)
 Price: See table below.

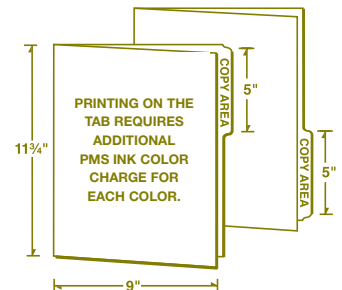

● 09-22 File Tab at Top
 09-23 File Tab at Bottom
 Price: See table below.

Judge a book by its cover...

The work you do will surely capture attention from others when presented in one of our distinctive report covers. Perfect for presenting proposals, contracts and income tax information.

Product Information

Artwork / Template

Price is based on customer supplied files (in acceptable programs with hard copy). Files **MUST** be submitted on the design template for the item ordered. See page 47 for more information.

new Lower prices on four color process!

Stock

Base stocks are included in price. See table below for additional charges when using Group A, B or C stocks. Refer to stock selection groups on inside back cover.

Production Time

7 working days. Schedules can often be adjusted based on the specifics of your order. Tell us what you need.

Blind Embossed Headings

FREE on foil stamped or embossed orders. Your choice of one heading (see list on page 3) positioned diagonally in the upper left corner of the front cover.

Additional Information

Can be found on pages 47 and 48.

Spine Attachments

Available in any of our Felt, Smooth, Vertical, Tweed, Hopsack, Linen, Cordwain and Oxford stocks. Indicate your stock and color choice when ordering. Refer to additional charge in the price grid below. Requires additional production time.



ONE-PIECE REPORT COVER PRICES

BASES	250	500	1000	1500	2000	2500	3000	5000	7500	10000
Print - One PMS Color	\$ 363	453	620	828	1095	1252	1378	2140	2703	3255
Print - Two PMS Colors	\$ 502	608	795	1025	1322	1515	1663	2468	3155	3810
Four Color Process	\$ 988	1147	1375	1545	1753	1955	2207	2962	3568	4455
Foil Stamp or Emboss - 25 sq. in.	\$ 377	455	610	808	1028	1207	1380	2102	2768	3338
OPTIONS/ADD TO BASE										
Additional PMS/Heavy Ink Coverage (per side)	\$ 158	177	200	225	258	300	325	375	517	633
Group A Stocks	\$ 53	77	123	178	228	285	338	560	835	1112
Group B Stocks	\$ 75	115	203	293	390	488	585	975	1368	1700
Group C Stocks	\$ 97	152	303	455	592	730	875	1458	2188	2742
Aqueous Coating - Flood Gloss	\$ FREE	FREE	FREE	FREE	FREE	FREE	FREE	FREE	FREE	FREE
Spine Attachments	\$ 167	327	647	942	1255	1565	1873	3105	4613	6027

Please call for an estimate for: other stocks, laminating, UV coating, UV printing, larger foil/emboss areas or combining foil/emboss.

(R)

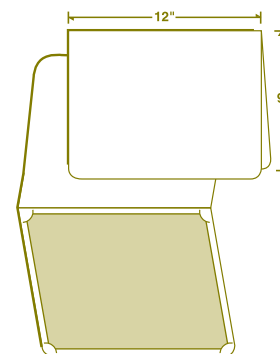

● 09-11 Certificate Cover

Price: See table below. Holds 8.5" x 11".

Give credit where credit is due...

At your next award presentation, slip your certificate into one of our stylish covers. It will help elevate the importance of the moment and add "extra special" value to the achievement rewarded. Used to hold certificates of appreciation, years of service, merit awards, promotion notices and even gift awards.

Product Information

Artwork / Template

Price is based on customer supplied files (in acceptable programs with hard copy). Files **MUST** be submitted on the design template for the item ordered.

Foil or Emboss: Submit one color art (no RGB or CMYK) in the size you want to appear on cover. Send vector (.EPS art) with all type converted to outlines. **No .JPG, .GIF or web images.** See page 47 for more information.

Stock

Base stocks are included in price. See table below for additional charges when using Group A, B or C stocks. Refer to stock selection groups on inside back cover.

Production Time

7 working days. Schedule can often be adjusted based on the specifics of your order. Tell us what you need.

Additional Information

Can be found on pages 47 and 48.

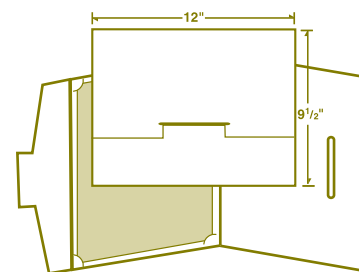

● 09-10 Portfolio Certificate Cover

Wrap around cover with self-forming easel.

Price: Base price *plus* the item upcharge shown in table below. Holds 8.5" x 11".

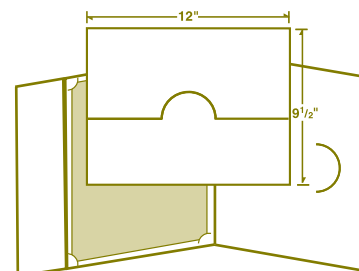

● 09-16 Fold-Up Closure Notch

Price: Base price *plus* the item upcharge shown in table below. Holds 8.5" x 11".

Expect More. GET MORE.

If you need a smaller cover for a 3.5" x 8.5" certificate or business check, call for an estimate on **Item 09-17**.



Lower prices on four color process!

CERTIFICATE COVER PRICES

BASES	250	500	1000	1500	2000	2500	3000	5000	7500	10000
Print - One PMS Color	\$ 363	453	620	828	1095	1252	1378	2140	2703	3255
Print - Two PMS Colors	\$ 502	608	795	1025	1322	1515	1663	2468	3155	3810
Four Color Process	\$ 988	1147	1375	1545	1753	1955	2207	2962	3568	4455
Foil Stamp or Emboss - 25 sq. in.	\$ 377	455	610	808	1028	1207	1380	2102	2768	3338
OPTIONS / ADD TO BASE										
Additional PMS/Heavy Ink Coverage (per side)	\$ 158	177	200	225	258	300	325	375	517	633
Group A Stocks	\$ 53	77	123	178	228	285	338	560	835	1112
Group B Stocks	\$ 75	115	203	293	390	488	585	975	1368	1700
Group C Stocks	\$ 97	152	303	455	592	730	875	1458	2188	2742
Item Upcharge for 09-10, 09-16	\$ 20	42	82	123	163	205	245	408	613	817
Aqueous Coating - Flood Gloss	\$ FREE	FREE	FREE	FREE	FREE	FREE	FREE	FREE	FREE	FREE

Please call for an estimate for: other stocks, laminating, UV coating, UV printing, larger foil/emboss areas or combining ink with foil/emboss.

(R)

SMALL PRESENTATION FOLDERS



Need a more compact folder?

Our line of small presentation folders packs the same promotional punch as our larger folders in an easy to hold, convenient size. **Stepped inserts** (page 24) are a great addition when you have a variety of services and benefits to explain. **Conformer® Expansion Item 48-65** is the perfect fit when added capacity is needed. Very popular with banks, credit unions and temporary staffing agencies.

Product Information

Printing PMS (limited graphics)

Price includes limited coverage of 30% or less of the surface area of the front and back cover plus pockets in one or two PMS ink color(s). No bleeds; copy must remain 3/8" from edges. If using heavier ink coverage or bleeds, add heavy ink coverage charge found in the price table below. Orders **MUST** specify a PMS number or a color match charge will be applied.

Artwork / Template

Price is based on customer supplied files (in acceptable programs with hard copy). Files **MUST** be submitted on the design template for the item ordered.

Foil or Emboss: Submit one color art (no RGB or CMYK) in the size you want to appear on folder. Send vector (.EPS art) with all type converted to outlines. **No .JPG, .GIF or web images.** See page 47 for more information.

Stock

Base stocks are included in price. See table below for additional charges when using Group A, B or C stocks. Refer to stock selection groups on inside back cover.

Production Time

7 - 10 working days. Multiple processes require the most production time. Schedules can often be adjusted based on the specifics of your order. Tell us what you need.

Additional Information

Can be found on pages 47 and 48.

Business Card Slots (optional)

Horizontal, notched slots are available **FREE** on the pocket of your choice. Please specify when ordering.

Conformer® Expansion Products

A U.S. patent number is required to appear on all Conformer® Expansion Folders. We will automatically add this copy in small type to **Item 48-65**.

Blind Embossed Headings

FREE on foil stamped or embossed orders.

Your choice of one heading, positioned as shown below. Please be sure your artwork is at least 1/2" from the embossed heading. Call for an estimate when using on printed orders.



new Lower prices on four color process!

SMALL PRESENTATION FOLDER PRICES

BASES	250	500	1000	1500	2000	2500	3000	5000	7500	10000
Print - One PMS Color - Limited	\$ 332	412	553	720	897	1035	1163	1657	2053	2225
Print - Two PMS Colors - Limited	\$ 450	545	703	888	1090	1263	1392	1900	2390	2637
Four Color Process	\$ 1145	1248	1407	1565	1703	1978	2003	2585	3343	4262
Foil Stamp or Emboss - 6 sq. in.	\$ 400	448	610	782	942	1148	1223	1782	2173	2483
OPTIONS / ADD TO BASE										
Additional PMS / Heavy Ink Coverage (per side)	\$ 158	177	200	225	258	300	325	375	517	633
Four Color Process (2nd side)	\$ 838	893	963	1180	1215	1233	1247	1383	1647	1925
Group A Stocks	\$ 25	40	63	93	120	148	177	293	440	580
Group B Stocks	\$ 43	67	117	168	210	262	313	520	730	907
Group C Stocks	\$ 62	98	197	293	377	470	563	938	1407	1763
Item Upcharge for 48-10, 48-31, 48-34, 48-65	\$ 58	98	167	233	308	375	450	750	1125	1500
Item Upcharge for 68-01, 68-04, 68-34, 68-51	\$ 58	98	167	233	308	375	450	750	1125	1500
Aqueous Coating - Flood Gloss	\$ FREE	FREE	FREE	FREE	FREE	FREE	FREE	FREE	FREE	FREE

Please call for an estimate for: other stocks, UV coating, UV printing, larger foil/emboss areas or combining ink with foil/emboss.

(R)

SMALL PRESENTATION FOLDERS

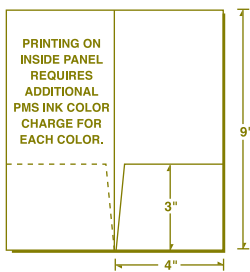

● **48-01, 48-04 4" x 9" Pocket Folder**
48-01 Two Pockets (shown)
48-04 One Right Pocket
 Price: See table on page 20.

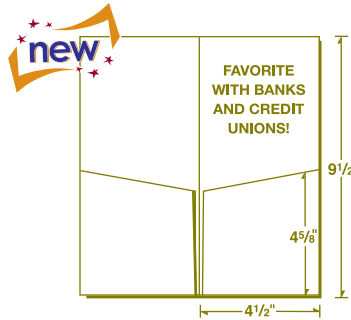

● **48-10 Angled Pockets**
 Price: Base price *plus* the item upcharge shown in table on page 20.

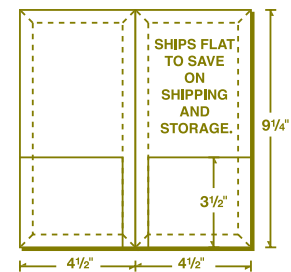

● **48-65 Conformer® Expansion Folder**
 Unique design expands to hold 1/8" per pocket.
 Price: Base price *plus* the item upcharge shown in table on page 20.

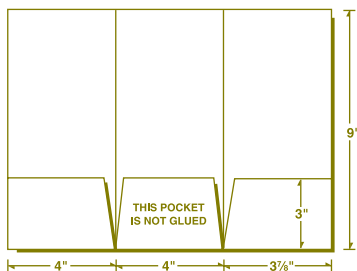

● **48-31 Three Panels, Three Pockets**
 Price: Base price *plus* the item upcharge shown in table on page 20.

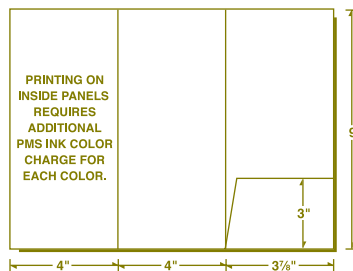

● **48-34 Three Panel, One Right Pocket**
 Price: Base price *plus* the item upcharge shown in table on page 20.

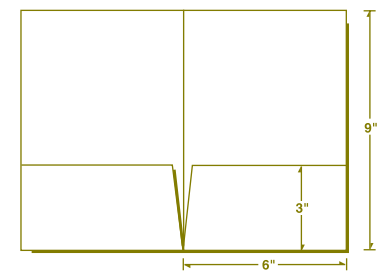

● **68-01 Two Pocket 6" x 9"**
 Price: Base price *plus* the item upcharge shown in table on page 20.

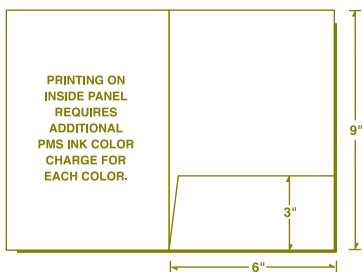

● **68-04 One Right Pocket**
 Price: Base price *plus* the item upcharge shown in table on page 20.

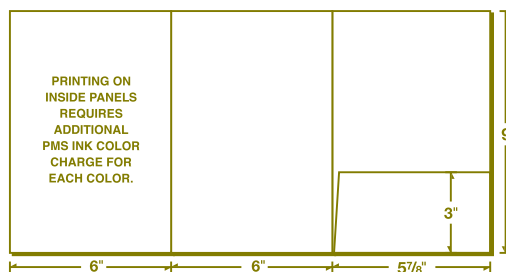

● **68-34 Three Panel, One Right Pocket**
 Price: Base price *plus* the item upcharge shown in table on page 20.

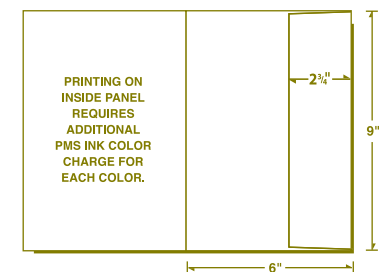

● **68-51 Portrait or Landscape Pocket**
 Specify portrait or landscape format when ordering.
 Price: Base price *plus* the item upcharge shown in table on page 20.

HOTEL KEY OR CARD HOLDERS



Add MORE value to every card...

A direct customer contact is made with each hotel key, membership, benefit or gift card you distribute. Why not maximize the moment by using one of our card holders? Add focus to other important information such as:

- Business Hours
- Special Services
- Check-out Times
- Car Rental Info
- Room Service & Directory Numbers
- Traveler's Safety Tips
- Restaurant & Tourist Attractions

Product Information

Printing PMS (limited graphics)

Price includes limited coverage of 30% or less of the surface area of the front and back covers plus pockets in one or two PMS ink color(s). No bleeds; copy must remain 3/8" in from edges. If using heavier ink coverage or bleeds, add heavy ink coverage charge found in the price table below. Orders **MUST** specify a PMS number or a color match charge will be applied.

Artwork / Template

Price is based on customer supplied files (in acceptable programs with hard copy). Files **MUST** be submitted on the design template for the item ordered. See page 47 for more information.

Stock

Base stocks are included in price. See table below for additional charges when using Group A, B or C stocks. Refer to stock selection groups on inside back cover.

Production Time

10 working days. Schedules can often be adjusted based on the specifics of your order. Tell us what you need.

Additional Information

Can be found on pages 47 and 48.

Expect More. GET MORE.

On a budget? **Item 07-01** and **Item 19-01** on page 43 provide an economical way to hold library cards, fishing licenses, gift cards and more.



HOTEL KEY OR CARD HOLDER PRICES

BASES	2500	3000	5000	7500	10000	15000	20000	25000	50000
Print - One PMS Color - Limited	\$ 957	1125	1288	1708	1823	2243	2793	2975	5497
Print - Two PMS Colors - Limited	\$ 1123	1292	1455	1875	1990	2452	3002	3308	5913
Four Color Process	\$ 1660	1823	2027	2335	2742	3208	3670	3907	6505
Foil Stamp or Emboss - 6 sq. in.	\$ 945	1095	1342	1778	2147	2843	3558	4160	7297
OPTIONS / ADD TO BASE									
Additional PMS Ink (per side) - Limited	\$ 200	225	275	325	367	400	433	500	583
Heavy Ink Coverage (per side)	\$ 200	225	275	325	367	400	433	500	583
Group A Stocks	\$ 148	177	293	440	580	750	917	1042	1833
Group B Stocks	\$ 262	313	520	730	907	1375	1833	2292	4167
Group C Stocks	\$ 470	563	938	1407	1763	2250	3000	3750	7500
Aqueous Coating - Flood Gloss	\$ FREE	FREE	FREE	FREE	FREE	FREE	FREE	FREE	FREE

Please call for an estimate for: other stocks, UV coating, UV printing, larger foil/emboss areas or combining ink with foil/emboss.

(R)

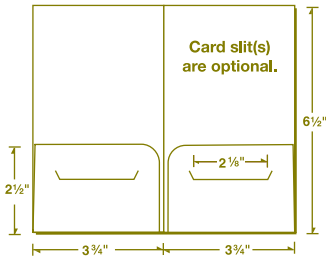

● **48-11 Hotel Key or Card Holder**

Price: See table on page 22.

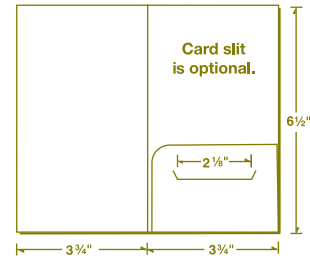

● **48-14, 48-13 Key or Card Holder with One Pocket**

48-14 With one pocket on the right side (shown).

48-13 With one pocket on the left side.

Price: See table on page 22.

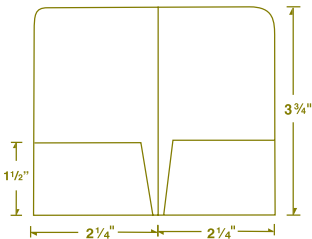

● **48-03 Mini Folder**

Holds a 2" x 3 1/2" size card.

Price: See table on page 22.

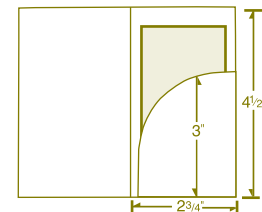

● **48-05 Curved One Pocket Folder**

Holds a 2 1/8" x 3 3/8" size card.

Price: See table on page 22.

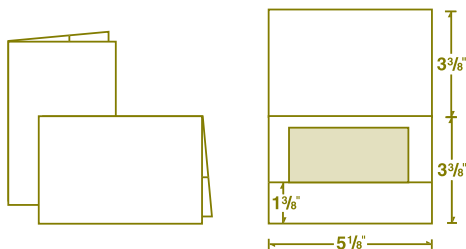

● **27-03 Card Holder**

Holds a 2 1/8" x 3 3/8" size card.

Price: See table on page 22.

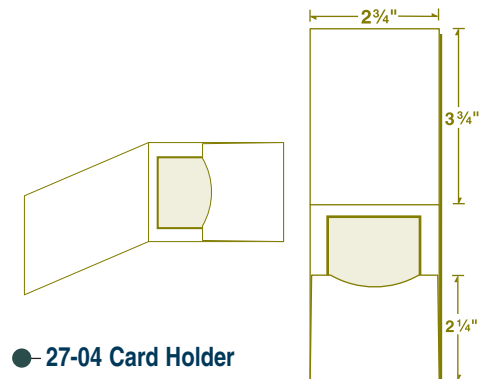

● **27-04 Card Holder**

Holds a 2 1/8" x 3 3/8" size card.

Price: See table on page 22.

STACKED INSERTS



Product Information - Small Presentation Folder Inserts

Printing - PMS Colors - Limited Graphics

The print base shown in table includes one or two PMS ink color(s) in any location on the front side of each insert. Line copy, logos, small screen areas, simple color traps and bar bleeds at top of insert are allowed. Orders **MUST** specify a PMS number or a color match charge will be applied.

Artwork

Price is based on customer supplied files (in acceptable programs with hard copy). See page 47 for more information. Files must be to size with a minimum bleed of 1/8". **Live copy (type) should be 1/4" away from cut edge.**

Stock

Choose from 80 lb. white C2S gloss text or 80 lb. white matte text.

Production Time

10 working days. Collating and inserting adds up to 5 working days. Please call with information specific to your order.

Additional Information

Can be found on pages 47 and 48.

Product Information - Large Presentation Folder Inserts

Printing - Four Color Process

The print base shown in table includes four color process printing only in any location on the front side of each insert.

Artwork

Price is based on customer supplied files (in acceptable programs with hard copy). See page 47 for more information. Files must be to size with a minimum bleed of 1/8". **Live copy (type) should be 1/4" away from cut edge.**

Stock

Choose from 80 lb. white C2S gloss text or 80 lb. white matte text.

Production Time

10 working days. Collating and inserting adds up to 5 working days. Please call with information specific to your order.

Additional Information

Can be found on pages 47 and 48.

INSERT PRICES - SETS FOR SMALL PRESENTATION FOLDERS

12-00 (4" x 9")		250	500	1000	1500	2000	2500	3000	5000	7500	10000
Up to 5 inserts	Print - One PMS Color - Limited	\$ 408	438	487	535	583	632	680	873	1115	1357
	Print - Two PMS Colors - Limited	\$ 575	608	663	720	775	830	887	1108	1387	1665
	Four Color Process	\$ 1158	1298	1453	1608	1763	1918	2073	2693	3468	4243
	Collating Upcharge	\$ 30	58	117	175	233	292	350	583	875	1167
	Inserting Upcharge	\$ 25	50	100	150	200	250	300	500	750	1000
From 6-10 inserts	Print - One PMS Color - Limited	\$ 433	490	582	675	767	860	952	1322	1785	2247
	Print - Two PMS Colors - Limited	\$ 605	668	772	877	980	1085	1188	1605	2127	2647
	Four Color Process	\$ 1245	1357	1557	1757	1957	2157	2357	3157	4157	5157
	Collating Upcharge	\$ 38	75	150	225	300	375	450	750	1125	1500
Inserting Upcharge	\$ 38	75	150	225	300	375	450	750	1125	1500	

INSERT PRICES - SETS FOR LARGE PRESENTATION FOLDERS

12-00 (8 1/2" wide)		250	500	1000	1500	2000	2500	3000	5000	7500	10000
Up to 8 inserts	Four Color Process 1 insert	\$ 217	222	263	307	348	390	432	600	810	1020
	Four Color Process 2 inserts	\$ 433	443	528	612	697	780	863	1200	1620	2042
	Four Color Process 3 inserts	\$ 648	665	792	918	1043	1170	1297	1800	2432	3062
	Four Color Process 4 inserts	\$ 865	888	1055	1223	1392	1560	1728	2400	3242	4082
	Four Color Process 5 inserts	\$ 1082	1110	1320	1530	1740	1950	2160	3002	4052	5103
	Four Color Process 6 inserts	\$ 1298	1332	1583	1835	2088	2340	2592	3602	4862	6123
	Four Color Process 7 inserts	\$ 1515	1553	1847	2142	2437	2730	3025	4202	5672	7143
	Four Color Process 8 inserts	\$ 1730	1775	2112	2448	2783	3120	3457	4802	6483	8163
	Collating Upcharge	\$ 17	25	33	50	67	83	100	167	250	333
	Inserting Upcharge	\$ 33	67	100	150	200	250	300	500	750	1000

Please call for an estimate for: other stocks, UV printing, custom die-cuts, heavy coverage, foil, emboss, or UV coating.

(R)



Product Information

Specifications

Stitched brochures are available **ONLY** with a folder order. They can be stitched into most large presentation folders or report covers. Available in 4, 8, 12 or 16 page brochures. Add the price in table below to the cost of your folder or cover order. Includes stitching the brochure into the item.

Stock

Choose from 80 lb. white C2S gloss text or 80 lb. white matte text. Call for an estimate on other stocks.

Production Time

Add 3 – 5 working days to folder production. Schedules can often be adjusted based on the specifics of your order. Tell us what you need.

Artwork

Price is based on customer supplied files (in acceptable programs with hard copy). See page 47 for more information. Files must be to size with a minimum bleed of 1/8". **Live copy (type) should be 1/4" away from cut edge or fold.**

Recommended Brochure Sizing

87/8" x 117/8": Use with 12" high *square corner* large presentation folders.

81/2" x 11": Use with 12" high *round corner* large presentation folders or large presentation folders less than 12" tall.

Additional Information

Can be found on pages 47 and 48.

Two Sizes to Choose From:

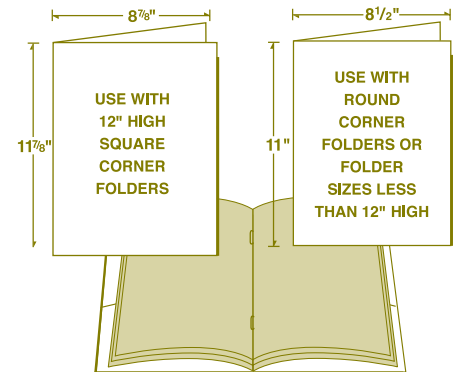

4-PAGE STITCHED BROCHURES (ADD TO FOLDER PRICE)								
4-PAGE	250	500	1000	1500	2000	2500	3000	5000
Print – One PMS Color	\$ 547	625	818	983	1132	1315	1490	2187
Print – Two PMS Colors	\$ 547	625	818	983	1132	1315	1490	2187
Four Color Process	\$ 1105	1163	1398	1555	1762	1928	2157	3078
Aqueous Coating - Flood Gloss	\$ FREE	FREE	FREE	FREE	FREE	FREE	FREE	FREE
8-PAGE STITCHED BROCHURES (ADD TO FOLDER PRICE)								
8-PAGE	250	500	1000	1500	2000	2500	3000	5000
Print – One PMS Color	\$ 783	913	1220	1448	1690	1928	2223	3348
Print – Two PMS Colors	\$ 783	913	1220	1448	1690	1928	2223	3348
Four Color Process	\$ 1422	1483	1662	2017	2222	2507	2830	4083
Aqueous Coating - Flood Gloss	\$ FREE	FREE	FREE	FREE	FREE	FREE	FREE	FREE
12-PAGE STITCHED BROCHURES (ADD TO FOLDER PRICE)								
12-PAGE	250	500	1000	1500	2000	2500	3000	5000
Print – One PMS Color	\$ 1242	1428	1695	1988	2313	2455	2920	4118
Print – Two PMS Colors	\$ 1242	1428	1695	1988	2313	2455	2920	4118
Four Color Process	\$ 2388	2597	2960	3457	3600	4033	4448	5883
Aqueous Coating - Flood Gloss	\$ FREE	FREE	FREE	FREE	FREE	FREE	FREE	FREE
16-PAGE STITCHED BROCHURES (ADD TO FOLDER PRICE)								
16-PAGE	250	500	1000	1500	2000	2500	3000	5000
Print – One PMS Color	\$ 1315	1517	1850	2218	2607	2887	3377	4900
Print – Two PMS Colors	\$ 1315	1517	1850	2218	2607	2887	3377	4900
Four Color Process	\$ 2598	2833	3258	3678	4028	4630	4975	6843
Aqueous Coating - Flood Gloss	\$ FREE	FREE	FREE	FREE	FREE	FREE	FREE	FREE

Please call for an estimate for: other sizes, other stocks, UV coating, UV printing, foil or emboss.

(R)

THREE-RING PAPER BINDERS

FOR ADDED DURABILITY ALL BINDERS HAVE REINFORCED TABS AT SPINE



Paper or Plastic?

If you need an economical alternative to poly or vinyl binders, the answer is paper. Made from durable laminated stock, they can be printed with full color graphics, foil stamped or embossed.

It's easy to coordinate your paper binder with the look of other printed materials. Their lighter weight reduces shipping costs. Ideal for training programs, product manuals, benefit information and more.

Product Information

Artwork / Template

Price is based on customer supplied files (in acceptable programs with hard copy). Files **MUST** be submitted on the design template for the item ordered. See page 47 for more information.

Stock

Binders are produced on 19 pt. gloss laminated C1S white cover stock. This stock is included in the base prices shown in the grid below.

Lamination

Plastic GLOSS film lamination is included in the base price of all binders. Matte lamination can be added for the additional charge in the price grid below.

Production Time

5000 or less: 10 working days.
Larger quantities: 15 – 20 working days.
Schedules can often be adjusted based on the specifics of your order. Tell us what you need.

Additional Information

Can be found on pages 47 and 48.

Pocket Options

A variety of card slots and brochure slit options are available **FREE** of charge in binders with pockets. See page 16.

Ring Mechanisms

Base price includes 1/2" PLASTIC ring mechanism. Additional sizes and metal rings can be added for the additional charge in the price grid below.



Metal: 1/2", 3/4", 1"



Plastic: 1/2", 3/4", 1"

Expect More. GET MORE.

When you need "plastic" give us a call. A large variety of poly, vinyl and clearview options are available.



Lower prices on four color process!

BINDER PRICES

BASES (with pockets)	250	500	1000	1500	2000	2500	3000	5000	7500	10000
Print - One PMS Color	\$ 1103	1567	2540	3687	4855	6018	7090	11190	13323	16782
Print - Two PMS Colors	\$ 1262	1743	2740	3912	5113	6318	7415	11565	13840	17415
Four Color Process	\$ 1828	2287	3122	4152	5237	6497	7743	12092	14237	18102
Foil Stamp or Emboss - 25 sq. in.	\$ 1100	1552	2678	3813	4925	6025	7125	11325	13670	17622
BASES (without pockets)										
Print - One PMS Color	\$ 835	1290	2147	3157	4158	5138	6060	9833	12480	15938
Print - Two PMS Colors	\$ 993	1467	2347	3382	4417	5438	6385	10208	12997	16572
Four Color Process	\$ 1553	2062	2907	3910	4900	6107	7322	11533	14198	18070
Foil Stamp or Emboss - 25 sq. in.	\$ 1100	1552	2678	3813	4925	6025	7125	11325	13670	17622
OPTIONS/ADD TO BASE										
Additional PMS/Heavy Ink Coverage (per side)	\$ 158	177	200	225	258	300	325	375	517	633
R.E. (Reinforced Edge) Upcharge for 88-71, 88-75, 99-71	\$ 75	88	163	240	305	338	353	382	408	420
Item Upcharge for 88-59	\$ 307	357	445	633	815	947	1120	1772	2452	3023
Lamination - Plastic Matte	\$ 75	107	168	232	293	355	417	563	937	1248
3/4" Plastic Ring Mechanism	\$ 18	37	72	107	140	175	210	350	525	700
1" Plastic Ring Mechanism	\$ 40	80	160	240	320	400	480	800	1200	1600
1/2" or 3/4" Metal Ring Mechanisms	\$ 100	200	400	600	800	1000	1200	2000	3000	4000
1" Metal Ring Mechanism	\$ 125	250	500	750	1000	1250	1500	2500	3750	5000

Please call for an estimate for: other stocks, larger foil/emboss areas or combining ink with foil/emboss.

(R)

THREE-RING PAPER BINDERS

BINDER SIZE VARIES WITH RING CAPACITY. REQUEST A DESIGN TEMPLATE.

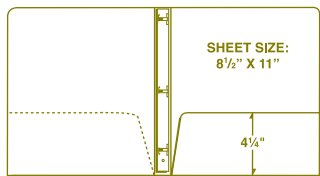

● **88-01, 88-04 Pocket Binder**

88-01 Two pockets (shown).
88-04 One right pocket.
 Price: See table on page 26.

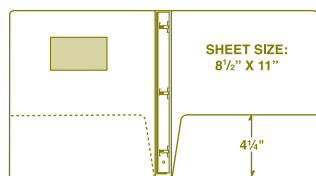

● **88-09, 88-49 Window Pocket Binder**

88-09 Two pockets (shown).
88-49 One right pocket.
 Price: See table on page 26.

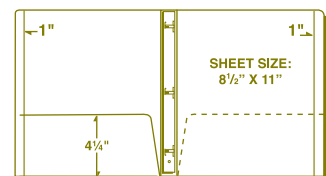

● **88-71, 88-75 Reinforced Edges Pocket Binder**

88-71 Two pockets (shown).
88-75 One Left pocket.
 Price: Base price *plus* the R.E. upcharge shown in table on page 26.

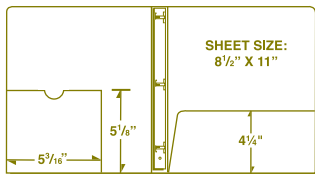

● **88-05 5" CD Sleeve Pocket Binder**

Price: See table on page 26.
 Production time varies based on quantity.

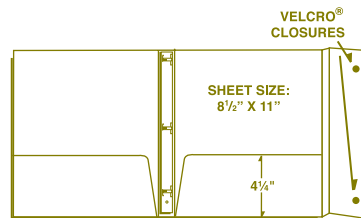

● **88-07 Portfolio Flap Pocket Binder**

Price: Call for an estimate.
 Production time varies based on quantity.

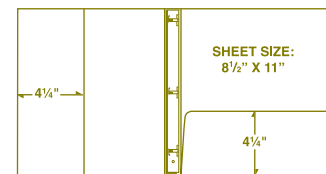

● **88-59 Vertical & Regular Pocket Binder**

Price: Base price *plus* the item upcharge shown in table on page 26.
 Production time varies based on quantity.

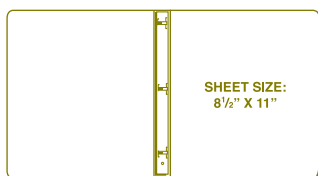

● **99-01 Binder**

Price: See table on page 26.

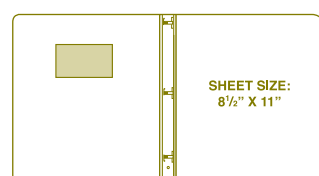

● **99-09 Binder with Window**

Price: See table on page 26.

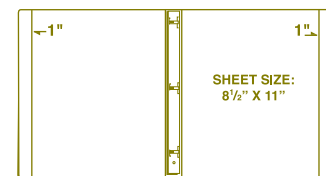

● **99-71 Reinforced Edges Binder**

Price: Base price *plus* the R.E. upcharge shown in table on page 26.



Basic index tabs:

- Mylar covered tab extends 1/2" from sheet edge
- Drilled with two, three or four 5/16" holes
- Sheet size: 11" x 8 1/2" or 8 1/2" x 5 1/2"
- Tabs printed two sides in black ink
- Reinforced binding edge

Organize your way!

Index tabs organize important documents the way you want to organize them. Each order is custom printed and tab cut to your specifications. Mylar coating on the tabs helps prevent wear and makes them rigid for easy flipping. A perfect binder companion.

Product Information

Printing (Tab Only)

Price includes printing (type only) on the front and back of tab area, in black ink. See table below for additional charge to print in PMS ink color(s) or for solid reverse printing on tabs. Call for an estimate if you need printing on the body of your divider.

Artwork (Tab Only)

Tab area line copy is typeset **FREE**.

Stock

Standard 90 lb. White Index is included in price. See table below for additional charges when using 90 lb. Colored Index or 110 lb. White Index. Call for an estimate on poly tabs or special stock.

Production Time

Varies, based on quantity. Most standard 90 lb. White Index orders ship in 5 working days. Call with information specific to your order. Tell us what you need.

Mylar

Tabs are covered with clear or colored mylar. Refer to mylar colors on inside back cover. Write-on and toner receptive mylar are available, call for an estimate.

Additional Information

Can be found on pages 47 and 48.

Expect More. GET MORE.

Need a bit MORE than the basics? Four color process graphics, solid ink coverage, foil stamping, embossing, premium stocks and custom tab cuts are all available. Call for an estimate.



BASIC INDEX TAB PRICES (PER SET)

TABS/SET	50	100	150	250	500	1000	1500	2000	2500	3000	5000
1	\$ 4.400	2.200	1.467	0.880	0.480	0.300	0.285	0.257	0.238	0.229	0.161
2	\$ 4.480	2.240	1.493	0.896	0.540	0.413	0.393	0.355	0.336	0.327	0.252
3	\$ 4.560	2.280	1.520	0.912	0.560	0.530	0.500	0.453	0.434	0.425	0.360
4	\$ 4.600	2.300	1.533	0.920	0.660	0.648	0.608	0.551	0.532	0.523	0.451
5	\$ 4.640	2.320	1.547	0.928	0.777	0.765	0.715	0.649	0.630	0.621	0.542
6	\$ 4.720	2.360	1.573	1.068	0.894	0.883	0.823	0.747	0.728	0.719	0.633
7	\$ 4.800	2.400	1.614	1.226	1.046	1.000	0.930	0.845	0.826	0.817	0.735
8	\$ 4.880	2.440	1.824	1.389	1.167	1.118	1.038	0.943	0.924	0.915	0.846
9	\$ 4.960	2.521	2.040	1.556	1.288	1.235	1.145	1.041	1.022	1.013	0.941
10	\$ 5.040	2.772	2.262	1.728	1.407	1.353	1.253	1.139	1.120	1.071	1.035
11	\$ 5.120	3.029	2.490	1.905	1.530	1.470	1.360	1.237	1.218	1.209	1.130
12	\$ 5.178	3.243	2.682	2.054	1.651	1.588	1.468	1.335	1.316	1.307	1.269
13	\$ 5.434	3.456	2.874	2.204	1.771	1.705	1.575	1.433	1.414	1.405	1.367
14	\$ 5.779	3.727	3.114	2.390	1.892	1.823	1.683	1.585	1.566	1.556	1.465
15	\$ 6.039	3.943	3.309	2.542	2.013	1.940	1.790	1.745	1.725	1.715	1.563

OPTIONS / ADDITIONAL COSTS

90 lb. colored index	add \$16.00 per 1000 tabs
110 lb. white index	add \$13.00 per 1000 tabs
PMS colored ink	add \$167.00 per color/per side

OPTIONS / ADDITIONAL COSTS

Solid Reverse Tab Printing	add \$53.00 per bank
Tab Extensions - 1/4", 3/8", 5/8"	add \$53.00 set-up
Collating	\$21.00 per 1000 tabs (\$50.00 min.)

Please call for an estimate for legal size tabs.

(R)

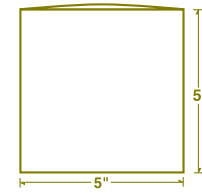

● **26-08 5" CD Sleeve**

Price: See table below.

Singularly Simple...

You need packaging for a single 5" disk. It's important that the packaging design be functional, but not attract more attention than your message. Our basic line of CD/DVD packaging includes a sleeve and several flap closure options and is just what you need!

Production Time

10 working days, except where noted. Schedules can often be adjusted based on the specifics of your order. Tell us what you need.

Additional Information

Can be found on pages 47 and 48.

Mailers

Let us know your mailing requirements prior to production. Spot coatings may be necessary if using inkjet. For durability, we recommend using 18 pt. C1S Semi-gloss White stock for the additional charge listed in table below.

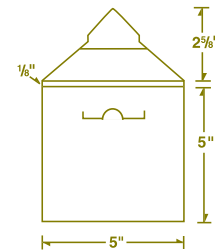

● **26-11 CD Tuck Flap Closure**

Price: See table below.

Product Information

Artwork / Template

Price is based on customer supplied files (in acceptable programs with hard copy). Files **MUST** be submitted on the design template for the item ordered. See page 47 for more information.

Stock

Base stocks are included in price. See table below for additional charges when using Group A, B or C stocks. Refer to stock selection groups on inside back cover.

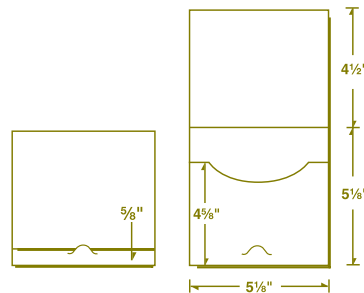

● **26-03 5" CD Cover**

Closure notch is optional.

Price: See table below.

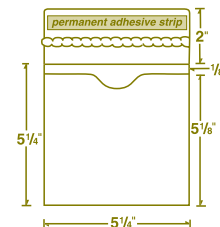

● **26-12 CD Mailer**

Price: Base price *plus* the item upcharge shown in table below.

Production time is 15 working days.

CD/DVD PACKAGING PRICES

BASES	250	500	1000	1500	2000	2500	3000	5000	7500	10000
Print - One PMS Color	\$ 438	577	683	770	860	957	1058	1497	2078	2730
Print - Two PMS Colors	\$ 577	732	858	967	1087	1220	1343	1825	2530	3285
Four Color Process	\$ 1218	1357	1462	1638	1720	1797	1880	2255	3287	4047
Foil Stamp or Emboss - 15 sq. in.	\$ 465	590	803	1073	1347	1627	1910	3037	4447	5825
OPTIONS / ADD TO BASE										
Additional PMS Ink Color (per side)	\$ 158	177	200	225	258	300	325	375	517	633
Heavy Ink Coverage (per side)	\$ 158	177	200	225	258	300	325	375	517	633
Group A Stocks	\$ 25	40	63	93	120	148	177	293	440	580
Group B Stocks	\$ 43	67	117	168	210	262	313	520	730	907
Group C Stocks	\$ 62	98	197	293	377	470	563	938	1407	1763
18 pt. C1S Semi-gloss White Stock	\$ 43	67	117	168	210	262	313	520	730	907
Item Upcharge for 26-12	\$ 38	65	132	197	263	328	395	658	987	1315
Aqueous Coating - Flood Gloss	\$ FREE	FREE	FREE	FREE	FREE	FREE	FREE	FREE	FREE	FREE
Varnish - Spot Gloss	\$ 158	177	200	225	258	300	325	375	517	633

Please call for an estimate for: paperboard mailers, other stocks, laminating, UV coating, UV printing, larger foil/emboss areas or combining ink with foil/emboss.

(R)



Packaging and a bit more...

When it's important that the complete package be just as engaging as the message, consider CD/DVD packaging with pockets or reinforced covers to expand your available information area.

Product Information

Artwork/Template

Price is based on customer supplied files (in acceptable programs with hard copy). Files **MUST** be submitted on the design template for the item ordered. See page 47 for more information.

Stock

Base stocks are included in price. See table below for additional charges when using Group A, B or C stocks. Refer to stock selection groups on inside back cover.

Production Time

Items 26-04, 26-05, 26-06 & 26-48: 10 working days. **Other Items:** 15 working days, except where indicated. Schedules can often be adjusted based on the specifics of your order. Tell us what you need.

Additional Information

Can be found on pages 47 and 48.

Conformer® Expansion Products

A U.S. patent number is required to appear on all Conformer® Expansion CD covers. We will automatically add this copy in small type to the back panel of **Item 26-14**.

Mailers

Let us know your mailing requirements prior to production. Spot coatings may be necessary if using inkjet. For durability, we recommend using 15 pt. C1S Semi-gloss White stock for the additional charge listed in table below.

Foam CD Buttons

Black or white foam CD buttons are included on **Item 26-10**. Please specify color when ordering.

Business Card Slots (optional)

Horizontal, notched style card slots are available **FREE** on the pocket of **Item 26-48**. Please specify when ordering.

Expect More. **GET MORE.**

Need a folder with a built-in CD sleeve?

See **Item 08-62** on page 6. For a binder with a built-in CD sleeve, see **Item 88-05** on page 27.

CD/DVD PACKAGING PRICES

BASES	250	500	1000	1500	2000	2500	3000	5000	7500	10000
Print - One PMS Color	\$ 538	685	877	1128	1375	1632	1887	2915	4200	5453
Print - Two PMS Colors	\$ 677	840	1052	1325	1602	1895	2172	3243	4652	6008
Four Color Process	\$ 1437	1560	1755	2148	2423	2727	3027	4365	5650	7075
Foil Stamp or Emboss - 15 sq. in.	\$ 480	620	903	1158	1460	1768	2080	3320	4872	6422
OPTIONS / ADD TO BASE										
Additional PMS Ink Color (per side)	\$ 158	177	200	225	258	300	325	375	517	633
Heavy Ink Coverage (per side)	\$ 158	177	200	225	258	300	325	375	517	633
Group A Stocks	\$ 25	40	63	93	120	148	177	293	440	580
Group B Stocks	\$ 43	67	117	168	210	262	313	520	730	907
Group C Stocks	\$ 62	98	197	293	377	470	563	938	1407	1763
15 pt. C1S Semi-gloss White Stock	\$ 25	40	63	93	120	148	177	293	440	580
Item Upcharge for 26-13, 26-17	\$ 58	115	230	345	460	573	687	1143	1715	2287
Aqueous Coating - Flood Gloss	\$ FREE	FREE	FREE	FREE	FREE	FREE	FREE	FREE	FREE	FREE
Varnish - Spot Gloss	\$ 158	177	200	225	258	300	325	375	517	633

Please call for an estimate for: paperboard mailers, other stocks, laminating, UV coating, UV printing, larger foil/emboss areas or combining ink with foil/emboss.

(R)

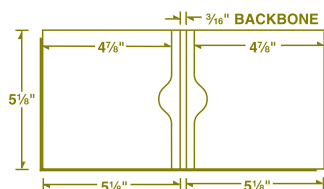

● **26-04 Double CD Holder**

Price: See table on page 30.

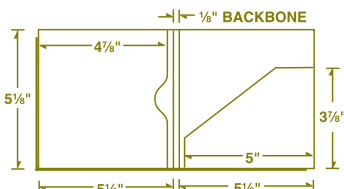

● **26-05, 26-06 Holder with Pocket**

26-05 Right pocket holds inserts (shown).

26-06 Left pocket holds inserts.

Price: See table on page 30.

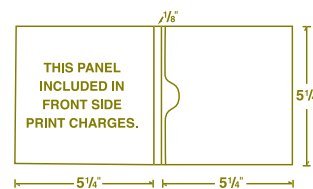

● **26-09 Reinforced Book Flap**

Price: See table on page 30.

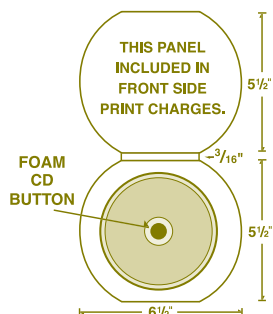

● **26-10 Reinforced Panel CD Holder**

Price: Call for an estimate.

Production time varies based on quantity.

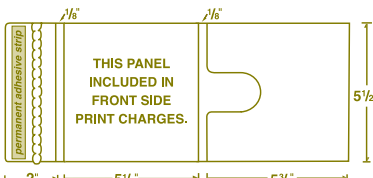

● **26-13 Reinforced Book Flap Mailer**

Price: Base price *plus* the item upcharge shown in table on page 30.

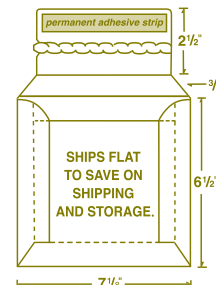

● **26-14 Conformer® Expansion Mailer**

Unique design expands to hold one regular or two slimline plastic jewel cases.

Price: See table on page 30.

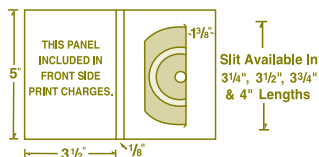

● **27-01 Mini CD / Card Holder**

Price: See table on page 30.

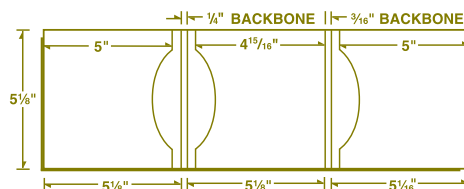

● **26-17 Triple CD Holder**

Price: Base price *plus* the item upcharge shown in table on page 30.

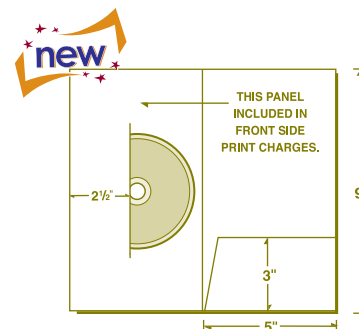

● **26-48 Reinforced CD Folder**

Price: See table on page 30.

CUSTOM PHOTO HOLDERS



Make it an event to remember...

Custom imprinted photo holders are perfect for fund raising promotions, golf outings, grand openings, company events, anniversary gatherings and more. Choose from three popular photo sizes.

Attention Realtors:

Make it a sale to remember with our stock real estate photo Thank You Cards. Insert a 4" x 6" photo of your customer's new home and attach your business card to the front. Sold in quantities as low as 50. Call for details on items shown below.



Product Information

Printing

Print base listed below includes printing in any location on the front and back covers and around the photo frame.

Artwork / Template

Price is based on customer supplied files (in acceptable programs with hard copy). Files **MUST** be submitted on the design template for the item ordered. See page 47 for more information.

Stock

Base stocks are included in price. See table below for additional charges when using Group A, B or C stocks. Refer to stock selection groups on inside back cover.

Production Time

10 working days. Schedules can often be adjusted based on the specifics of your order. Tell us what you need.

Additional Information

Can be found on pages 47 and 48.

Expect More. GET MORE.

Don't overlook the uses of a "Before and After" double photo holder. A great way to show customers the difference you've made. Used by orthodontists, landscape contractors, home remodelers, etc. Call for an estimate on **Item 03-06** shown below.



CUSTOM PHOTO HOLDER PRICES

BASES	150	250	500	1000	1500	2000	2500	3000	5000
Print - One PMS Color	\$ 440	477	590	852	1108	1365	1660	1930	3003
Print - Two PMS Colors	\$ 582	637	763	1137	1433	1687	2055	2372	3573
Four Color Process	\$ 1390	1405	1517	1738	2003	2222	2465	2692	3693
Foil Stamp or Emboss - 15 sq. in.	\$ 342	413	593	955	1317	1643	1997	2350	3760
OPTIONS / ADD TO BASE									
Additional PMS Ink Color (per side)	\$ 158	183	200	333	375	417	458	500	667
Heavy Ink Coverage (per side)	\$ 158	183	200	333	375	417	458	500	667
Group A Stocks	\$ 45	53	77	123	178	228	285	338	560
Group B Stocks	\$ 65	75	115	203	293	390	488	585	975
Group C Stocks	\$ 80	97	152	303	455	592	730	875	1458
Item Upcharge for 03-04, 03-05	\$ 17	17	33	67	100	133	167	200	333
Item Upcharge for 03-07, 03-08	\$ 50	50	100	200	300	400	500	600	1000
Aqueous Coating - Flood Gloss	\$ FREE	FREE	FREE	FREE	FREE	FREE	FREE	FREE	FREE

(R)

CUSTOM PHOTO HOLDERS

OUR STANDARD HOLDERS HAVE A DECORATIVE DECKLE CUT PHOTO FRAME!

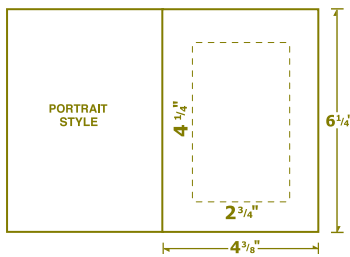

● **03-02 Portrait 3.5" x 5" Holder**
Price: See table on page 32.

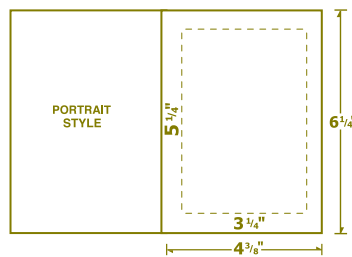

● **03-03 Portrait 4" x 6" Holder**
Price: See table on page 32.

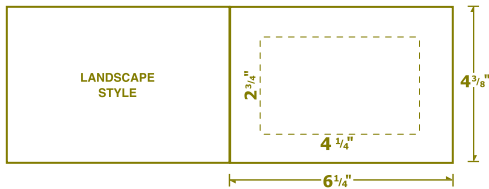

● **03-04 Landscape 3.5" x 5" Holder**
Price: Base price *plus* the item upcharge shown in table on page 32.

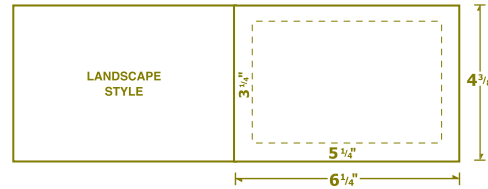

● **03-05 Landscape 4" x 6" Holder**
Price: Base price *plus* the item upcharge shown in table on page 32.

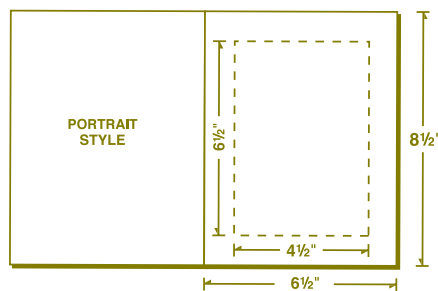

● **03-07 Portrait 5" x 7" Holder**
Price: Base price *plus* the item upcharge shown in table on page 32.

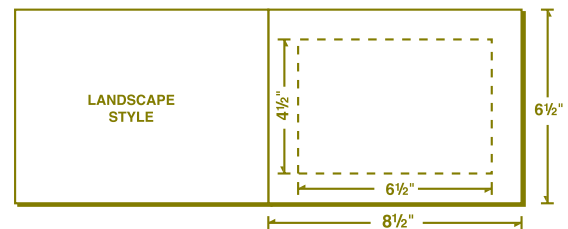

● **03-08 Landscape 5" x 7" Holder**
Price: Base price *plus* the item upcharge shown in table on page 32.

TOTES AND BOXES



Convenience and capacity...

The large capacity and convenience of our totes and boxes allows you to organize your materials, while adding an impressive dimension to your presentation. A perfect storage file when you have materials of varying sizes. Ideal for media kits, exposition and seminar handouts, mortgage, financial and benefit information.

Product Information

Artwork / Template

Price is based on customer supplied files (in acceptable programs with hard copy). Files **MUST** be submitted on the design template for the item ordered. See page 47 for more information.

Stock

Totes and boxes are produced on 18 pt. C1S Semi-gloss White stock. This stock is included in the base prices shown in the grid below.

Velcro® Closures and Handles

Black or white Velcro® fasteners are included in the price of all standard totes and boxes. Your choice of black or white handles on totes. Please specify color when ordering.

Production Time

10 – 15 working days, varies based on quantity. Please call for information specific to your order. Tell us what you need.

Additional Information

Can be found on pages 47 and 48.

Poly Boxes and Totes

A variety of sizes and styles are available with capacities from 1 1/4" to 3". Plain, silk screened or foil stamped with sonic welded or tuck tab construction. Call for an estimate.



Expect More. **GET MORE.**

Need extra durability and shine? Add gloss lamination to your tote or box for the additional charge in table below.

Need tab dividers for the inside of your box or tote? Call for an estimate.

new Lower prices on four color process and lamination!

TOTES & BOXES PRICES

BASES	250	500	1000	1500	2000	2500	3000	5000	7500	10000
Print - One PMS Color	\$ 1158	1595	2375	3257	4132	5010	5890	9407	13802	18193
Print - Two PMS Colors	\$ 1338	1797	2603	3512	4427	5352	6260	9833	14388	18915
Four Color Process	\$ 1825	2207	2792	3582	4403	5218	6055	8888	13052	16863
Foil Stamp or Emboss - 25 sq. in.	\$ 1132	1752	2830	4042	5252	6463	7675	12515	18572	24623
OPTIONS / ADD TO BASE										
Additional PMS/Heavy Ink Coverage (per side)	\$ 158	177	200	225	258	300	325	375	517	633
Item Upcharge for 36-02	\$ 792	875	992	1158	1400	1567	1658	2458	3683	4417
Item Upcharge for 37-01	\$ 1050	1475	1733	1833	2442	2808	3333	5442	8167	8917
Item Upcharge for 37-02	\$ 583	750	825	850	933	1000	1067	1200	1692	2183
Aqueous Coating - Flood Gloss	\$ FREE	FREE	FREE	FREE	FREE	FREE	FREE	FREE	FREE	FREE
Lamination - Plastic Gloss	\$ 205	323	560	797	1033	1270	1507	2453	3638	4822

Please call for an estimate for: other stocks, UV coating, UV printing, larger foil/emboss areas or combining ink with foil/emboss.

(R)

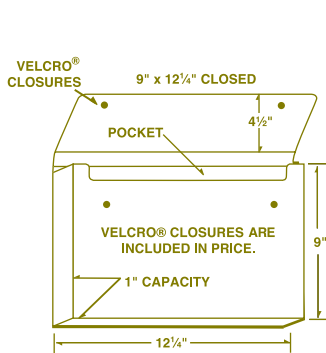

● **36-01 Box with Partial Flap**

Price: See table on page 34.

Production time: Varies, based on quantity.

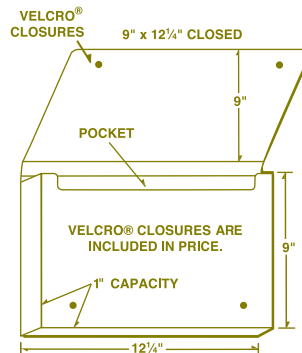

● **36-02 Box with Full Flap**

Price: Base price *plus* the item upcharge shown in table on page 34.

Production time: Varies, based on quantity.

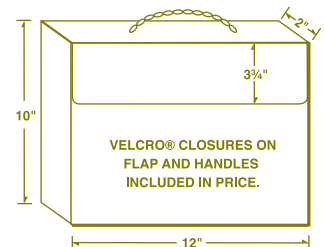

● **37-01 Horizontal Tote**

Price: Base price *plus* the item upcharge shown in table on page 34.

Production time: Varies, based on quantity.

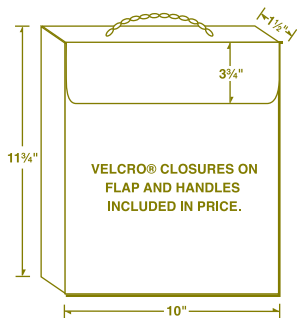

● **37-02 Vertical Tote**

Price: Base price *plus* the item upcharge shown in table on page 34.

Production time: Varies, based on quantity.

Need a Tuck Flap Box?

Special folding carton configurations such as tucks, auto closures, headers, windows and tab locks are available in quantities as low as 250. Call for an estimate.



Portable material packaging...

If you have odd size materials or need growing expansion capabilities, you need a portfolio. Great for employee benefits packages, building and design kits, lease and purchase agreements, cruise and resort packages.



Product Information

Artwork / Template

Price is based on customer supplied files (in acceptable programs with hard copy). Files **MUST** be submitted on the design template for the item ordered. See page 47 for more information.

Stock

Base stocks are included in price (150 lb. White or Manila tag is also available for base prices). See table below for additional charges when using Group A, B or C stocks. Refer to stock selection groups on inside back cover.

Production Time

Items 16-01, 16-02, 16-03, 16-05, 16-07, 35-11 and 35-12: 10 working days.

Items 16-04 and 16-09: 15 working days.

Items 35-13, 25-01, 25-03, 35-01 and 35-02:

Production time varies based on quantity. Call with information specific to your order. Multiple processes require the most production time.

Business Card Slots (optional)

Card slots are available on many portfolios. Request a design template.

Additional Information

Can be found on pages 47 and 48.

Conformer® Expansion Products

A U.S. patent number is required to appear on all Conformer® Expansion Portfolios. We will automatically add this copy in small type to the back panel of **Items 16-04, 16-05, 16-07 and 16-09.**

Mailers

Let us know your mailing requirements prior to production. Spot varnish may be necessary if using inkjet. For durability, we recommend using 15 pt. C1S Semi-gloss White stock. See additional charges in table below. Call for an estimate on heavy paperboard mailers.

Closure Options

Velcro®

Black or white Velcro® closures can be added to your portfolio for the additional charge shown in table below. Specify color when ordering. Deluxe portfolios use two 1/2" dot fasteners; expansion portfolios use a 1/2" dot and 1 1/2" strip fastener to accommodate product expansion. Additional production time is required.

Bandos

Black or white elastic band closures are available for the additional charge shown in table below. A small hole is added to the flap to anchor the bando. Bandos are unattached and ship bulk in each carton. Specify color when ordering.

PORTFOLIO PRICES

BASES	250	500	1000	1500	2000	2500	3000	5000	7500	10000
Print - One PMS Color	\$ 753	888	1242	1557	2002	2412	2815	4090	4708	6247
Print - Two PMS Colors	\$ 892	1043	1417	1753	2228	2675	3100	4418	5160	6802
Four Color Process	\$ 1557	1615	1905	2345	2727	3090	3527	4460	5242	6895
Foil Stamp or Emboss - 25 sq. in.	\$ 773	905	1288	1647	2077	2507	2927	4522	5017	6640
OPTIONS / ADD TO BASE										
Additional PMS/Heavy Ink Coverage (per side)	\$ 158	177	200	225	258	300	325	375	517	633
Group A Stocks	\$ 73	107	170	248	317	397	470	783	1175	1567
Group B Stocks	\$ 108	165	270	390	523	650	780	1300	1825	2267
Group C Stocks	\$ 138	217	433	650	833	1042	1250	2083	3125	3917
15 pt. C1S Semi-gloss White Stock	\$ 73	107	170	248	317	397	470	783	1175	1567
Item Deduction for 16-03	\$ -70	-83	-117	-145	-187	-225	-263	-383	-440	-585
Item Upcharge for 16-04, 16-09	\$ 168	212	293	365	447	517	578	835	1105	1455
Item Upcharge for 16-05, 16-07	\$ 75	85	110	137	172	212	242	348	408	538
Item Upcharge for 25-01, 25-03	\$ 110	218	435	648	862	1075	1290	2150	3225	4308
Item Upcharge for 35-01, 35-02	\$ 235	472	852	1173	1562	1908	2290	3817	5725	7475
Item Upcharge for 35-11, 35-12	\$ 105	195	340	465	620	775	930	1550	2325	3100
Aqueous Coating - Flood Gloss	\$ FREE	FREE	FREE	FREE	FREE	FREE	FREE	FREE	FREE	FREE
Varnish - Spot Gloss	\$ 158	177	200	225	258	300	325	375	517	633
Velcro® Closures	\$ 100	183	358	533	683	850	1025	1667	2500	3333
Bandos	\$ 70	132	255	382	510	637	765	1275	1910	2503

Please call for an estimate for: other stocks, laminating, UV coating, UV printing, larger foil/emboss areas or combining ink with foil/emboss.

(R)

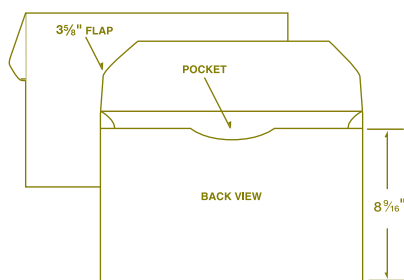

● **16-01, 16-02 Deluxe Portfolio**

16-01 Measures 10" x 15"

16-02 Measures 10" x 13"

Price: See table on page 36.

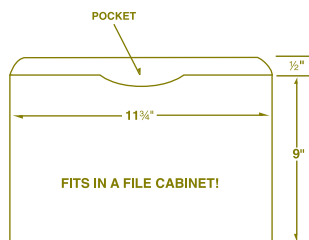

● **16-03 Portfolio File Jacket**

Top tab is not reinforced; sides are glued.

Price: Base price *minus* the item deduction shown in table on page 36.

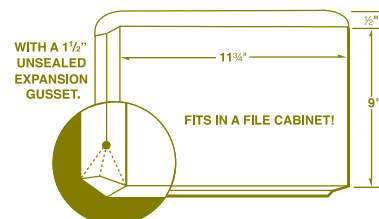

● **35-13 Reinforced Top Tab**

Ships flat with gusset out.

Price: Call for an estimate.

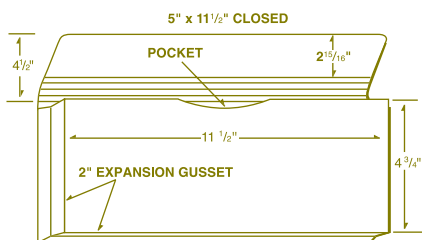

● **25-01 5" x 11 1/2" Portfolio**

Price: Base price *plus* the item upcharge shown in table on page 36.

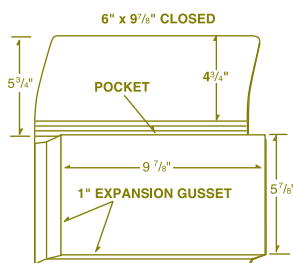

● **25-03 6" x 9 7/8" Portfolio**

Price: Base price *plus* the item upcharge shown in table on page 36.

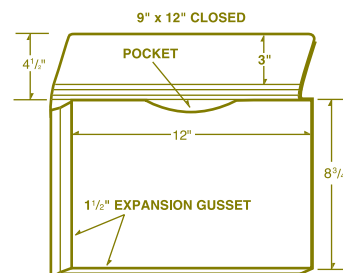

● **35-02 9" x 12" Portfolio**

Price: Base price *plus* the item upcharge shown in table on page 36.

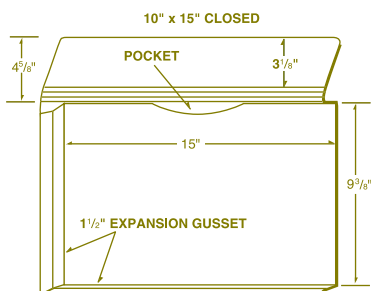

● **35-01 10" x 15" Portfolio**

Price: Base price *plus* the item upcharge shown in table on page 36.

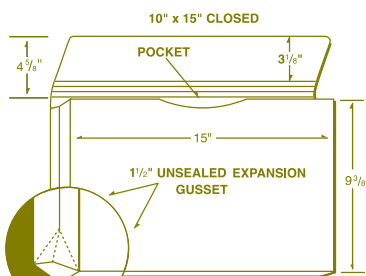

● **35-11 10" x 15" Portfolio**

Price: Base price *plus* the item upcharge shown in table on page 36.

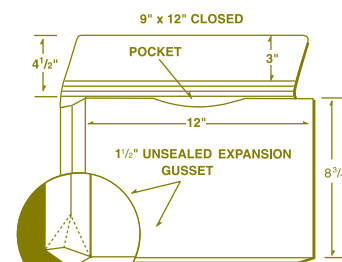

● **35-12 9" x 12" Portfolio**

Price: Base price *plus* the item upcharge shown in table on page 36.



Create a powerful branding statement...

Place a FedEx, Priority Mail or UPS shipping label directly onto your corporate branded **Conformer® Expansion Portfolio**. Promote your corporate identity instead of your courier's.

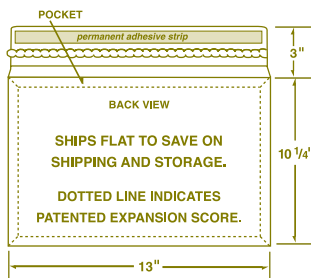

- **16-04, 16-09 Conformer® Expansion Zip Portfolio Mailer**
16-04 10 1/4" x 13" (shown). Holds 3/4".
16-09 9 1/2" x 12". Holds 1/2".
 Price: Base price *plus* the item upcharge shown in table on page 36.

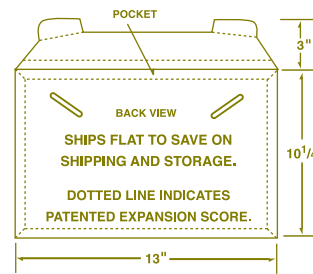

- **16-05, 16-07 Conformer® Expansion Tuck Portfolio Mailer**
16-05 10 1/4" x 13" (shown). Holds 3/4".
16-07 9 1/2" x 12". Holds 1/2".
 Price: Base price *plus* the item upcharge shown in table on page 36.

Choose a portfolio the easy way...

Pick a design. Send us your company imprint and logo information and we'll do the rest. Present your oversized loan closing documents in one convenient package!



Choose any PMS color!

Product Information

PRINTING: Price includes printing in one PMS ink color. Orders **MUST** specify a PMS number or a color match charge will be applied.

STOCK: Choose any Base or Group A stock.

ARTWORK: Imprint size is 3 1/2" x 5". We will typeset up to six lines of copy **FREE** or submit customer supplied files (in acceptable programs with hard copy). Submit one color art (no RGB or CMYK) in the size you want to appear on the portfolio. Send vector (.EPS art) with all type converted to outlines. **No .JPG, .GIF or web images.** See page 47 for more information.

PRODUCTION TIME: 7 working days.

● 16-01-005

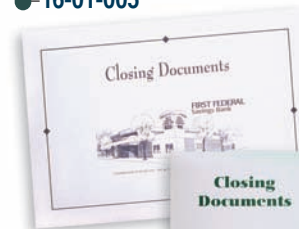

● 16-01-097



10" x 15" closed with a 3 5/8" flap.
 Four corner horizontal business card slots centered on flap.
 Price: See table below.

STANDARD DESIGN PORTFOLIO PRICES

	150	250	500	1000	1500	2000	2500	3000	5000	7500	10000
16-01-005	\$ 647	697	822	1148	1440	1852	2232	2603	3782	4355	5780
16-01-097	\$ 647	697	822	1148	1440	1852	2232	2603	3782	4355	5780

(R)

STANDARD DESIGNS BY INDUSTRY



We've done it for you...

We know you're busy. That is why we have numerous standard document folders already designed and ready to be chosen. All you need to do is send us your company imprint and logo information, and we'll do the rest!

Product Information

To Order

Add the three-digit standard design code to the four-digit product size number. For example, adding "090" to the "01-01" folder (01-01-090) designates the Service Record Folder shown on page 40.

Printing - Standard Ink Colors

Except where color limitations are noted, standard designs include imprinting in one standard ink color from the color chart at the bottom of the inside back cover.

Stock

Except where noted, choose any standard stock selection for Document Folders from the color chart at the bottom of the inside back cover.

Imprint Area - FREE Typesetting

Up to six lines of typeset copy are included **FREE**. The approximate size is 2 1/4" x 3 1/4". Imprints will be set in a standard typestyle that is compatible to the design ordered unless other specific instructions are given. Crest and service areas are also included where indicated.

Artwork

Submit supplied files (in acceptable programs with hard copy) as one color art (no RGB or CMYK). Send vector (.EPS art) with all type converted to outlines. **No .JPG, .GIF or web images.** See page 47 for more information.

Production Time

7 working days without card slots. 10 working days with card slots. Schedules can often be adjusted based on the specifics of your order. Tell us what you need.

Business Card Slots (optional)

Four corner style slits are available in limited items for an additional charge. Add \$75.00 list (R) per 1000 or per order if less than 1000. See position, item and style limitations below. Holds a standard 2" x 3 1/2" business card. When selecting card slots, be sure to check panel position of slots ordered with the copy design wanted. Card slots may cut through (or card may cover) standard copy for that design.

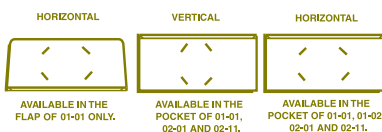

Additional Information

Can be found on pages 47 and 48.

Expect More. GET MORE.

Want to see even MORE standard document folder designs? At www.foldersolutions.com you're sure to find just the right design for your profession.



STANDARD DESIGN DOCUMENT FOLDER PRICES

	150	250	500	1000	1500	2000	2500	3000	5000	7500	10000
01-01-XXX on pages 40 - 41	\$ 127	160	237	327	482	635	763	878	1375	1950	2553
02-01-XXX on page 42	\$ 153	205	292	438	590	745	893	1043	1647	2358	3065
02-11-XXX on page 42	\$ 222	302	425	630	878	1128	1363	1610	2585	3738	4903
01-02-XXX on page 43	\$ 127	160	237	327	482	635	763	878	1375	1950	2553
07-01-XXX on page 43	\$ 120	137	173	207	307	372	460	533	805	1118	1440
19-01-XXX on page 43	\$ 120	137	173	207	307	372	460	533	805	1118	1440
45-01-XXX on page 43	\$ 185	235	320	493	675	855	1028	1207	1913	2738	3592
04-01-XXX on page 43	\$ 382	405	477	570	702	840	982	1127	1705	2388	3085
Business Card Slots	Add \$75.00 (R) per 1,000 or per order if less than 1,000										

(R)

STANDARD DESIGNS BY INDUSTRY

01-01 Folders – 4½" x 10¼" closed.

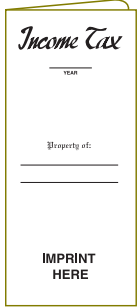

Face Only

● **009 Tax**

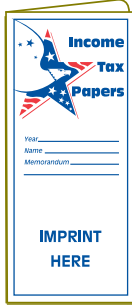

Face Only

● **502 Tax**

Standard red and blue ink on Bright White Felt Stock only.



Face Only

● **500 Patriotic**

Standard red and blue ink on Bright White Felt Stock only.



● **106 Tax**

Standard red and blue ink on Smooth White Stock only.

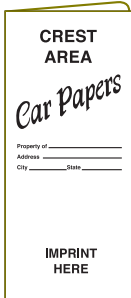

Face Only

● **001 Auto**



Face

● **092 Oil Change**

Standard red and black ink on Bright White Felt Stock only.

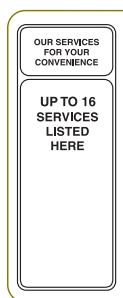

Flap

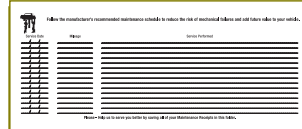

Pocket: Standard Form



Face

Pocket: Standard Form

● **091 Tire Center**

Standard red and black ink on Bright White Felt Stock only.

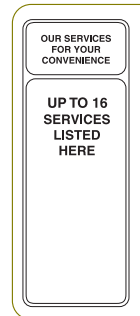

Flap

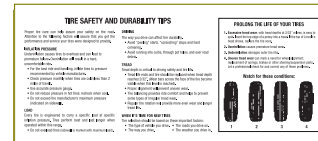

Face

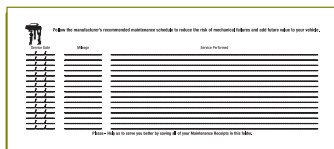

Pocket: Standard Form

● **090 Service & Maintenance**

Standard blue and black ink on Bright White Felt Stock only.

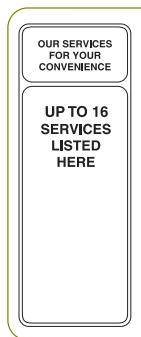

Flap



Face Only

● **015 Attorney**



Face

Pocket: Standard Form

● **018 Insurance**



Face Only

● **101 Attorney**

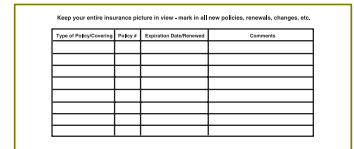

STANDARD DESIGNS BY INDUSTRY

01-01 Folders - 4 1/2" x 10 1/4" closed.



Face



Pocket: Standard Form

● 002 Travel

Standard red and blue ink on Marble Crush White Stock only.



Face



Pocket: Standard Form

● 055 Travel



Face



Pocket: Standard Form

● 070 Travel



Face



Pocket: Standard Form

● 073 Travel

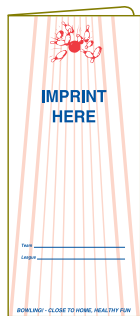

Face

● 019 Bowling

Standard red and blue ink on Marble Crush White Stock only.



Flap: Standard Form

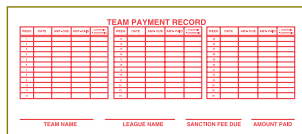

Pocket: Standard Form

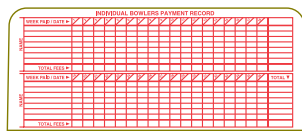

Inside Flap: Standard Form

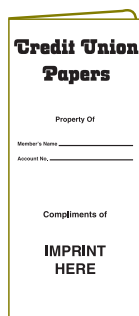

Face

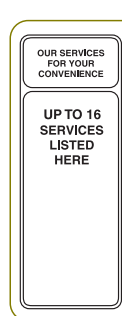

Flap

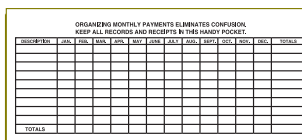

Pocket: Standard Form

● 022 Credit Union



Face Only

● 003 Realtor

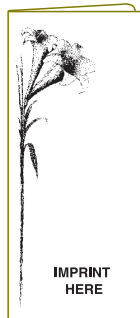

Face Only

● 308 Funeral

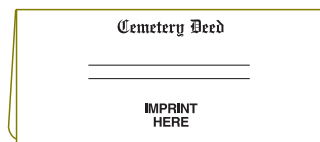

Face Only

● 016 Cemetery

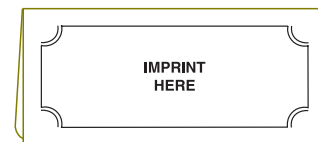

Face Only

● 303 Generic

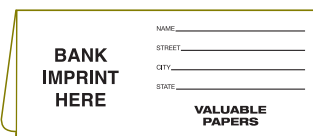

Face

● 130 Bank



Pocket: Standard Form



Face Only

● 304 Generic

STANDARD DESIGNS BY INDUSTRY

01-02 Folders – 4" x 9 1/4" closed.



Face



Pocket - Standard Form

●-050 Travel



Face



Pocket - Standard Form

●-055 Travel



Face



Pocket - Standard Form

●-071 Travel



Face



Pocket - Standard Form

●-072 Travel

●-45-01 Four-Pocket Folder – 4" x 9 1/4" closed.



Face

●-070 Travel



Face

●-055 Travel



Face

●-006 Travel

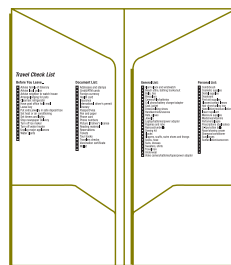

Inside view (open) - Checklist

Standard on 070, 055 and 006.

●-04-01 Receipt Holder - 3 3/4" x 7" closed.

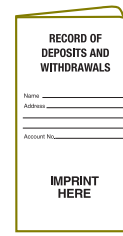

Face

●-001 Bank



Pocket: Standard Form

●-Optional Flap / Back Cover Forms for Items 07-01 & 19-01.



●-07-01 Card Holder – 2 1/2" x 4" closed.

Your imprint on the face and your choice of optional form on flap as shown (090, 091, 092, 093, 094, 095, 096).



●-19-01 License or Card Holder – 2 1/2" x 3 1/2" closed.

Your imprint on the front side and your choice of optional form on back as shown (090, 091, 092, 093, 094, 095, 096).

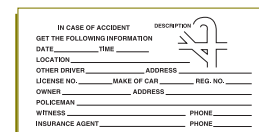

●-090

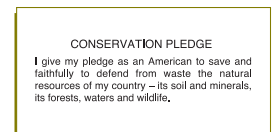

●-091

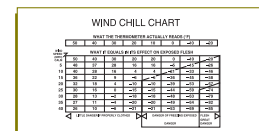

●-092



●-093



●-094

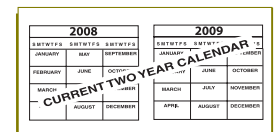

●-095

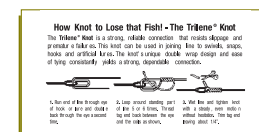

●-096



Be your own designer...

Completely customize your folder just the way you want it by writing your own copy and choosing your own graphics.

Simply select a folder style from page 45.

Provide us with your imprint and we will print and ship your job to you in as few as 10 working days. It's that easy!

Product Information

Artwork / Template

Price is based on customer supplied files (in acceptable programs with hard copy). Files **MUST** be submitted on the design template for the item ordered. Submit one color art (no RGB or CMYK) in the size you want to appear on the folder. Send vector (.EPS art) with all type converted to outlines. **No .JPG, .GIF or web images.** See page 47 for more information.

Printing Standard Ink Colors - Limited Graphics

Price includes one standard ink color from the color chart at the bottom of the inside back cover; in any location on the front side (flap, face and pocket). Line copy, logos, small screen areas and simple color traps are allowed. No heavy ink coverage, bleeds or tight registration allowed. Copy must remain 3/8" in from all edges. See chart below for additional standard ink color charges. On most items, second side printing (inside of flap) is available. Simply add the cost of one additional standard ink color charge for each standard color used on the second side.

Printing Non-Standard Ink Colors

Add \$80.00 list (R) to your order for each non-standard ink color (any PMS color not shown on inside back cover) used.

Foil Stamping And Embossing

Price includes a one color foil stamp area or one emboss area, up to 25 square inches, in any one location, on any panel that is 1/8" from any edge or fold. See the inside back cover for available foil colors. For best results, use type that is 8 pt. or larger and avoid screens or copy with tight intricate details.

Stock

Choose any standard stock selection for Document Folders from the color chart at the bottom of the inside back cover.

Production Time

10 working days. Schedules can often be adjusted based on the specifics of your order. Tell us what you need.

Business Card Slots (optional)

Four corner style slits are available in limited items for an additional charge. Add \$75.00 list (R) per 1000 or per order if less than 1000. See position, item and style information below. Holds a standard 2" x 3 1/2" business card.

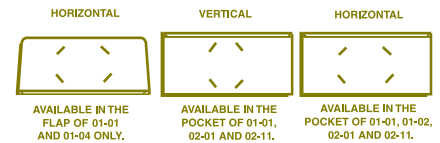

Additional Information

Can be found on pages 47 and 48.

DOCUMENT FOLDERS – CUSTOM DESIGN PRICES

ONE STANDARD INK COLOR	150	250	500	1000	1500	2000	2500	3000	5000	7500	10000
01-01, 01-02, 01-04	\$ 160	193	270	360	515	668	797	912	1408	1983	2587
02-01	\$ 187	238	325	472	623	778	927	1077	1680	2392	3098
02-10, 02-11	\$ 255	335	458	663	912	1162	1397	1643	2618	3772	4937
07-01, 19-01	\$ 153	170	207	240	340	405	493	567	838	1152	1473
45-01	\$ 218	268	353	527	708	888	1062	1240	1947	2772	3625
04-01	\$ 415	438	510	603	735	873	1015	1160	1738	2422	3118
19-02, 19-03, 19-04	\$ NA	NA	NA	558	750	942	1127	1292	1972	2812	3652
FOIL OR EMBOSS – 25 SQ. IN.											
01-01, 01-02, 01-04	\$ NA	278	327	490	652	815	978	1142	1793	2610	3425
02-01	\$ NA	287	342	522	702	880	1058	1238	1955	2850	3747
02-10, 02-11	\$ NA	308	383	603	825	1043	1265	1483	2367	3467	4570
45-01	\$ NA	293	355	548	740	933	1125	1317	2087	3048	4010
OPTIONS / ADD TO PRINT BASE											
Additional Standard Ink Color	\$ 37	38	43	63	73	85	103	112	152	212	275
Non-Standard Ink Color	Add \$80.00 (R) for each Non-Standard ink color.										
Business Card Slots	Add \$75.00 (R) per 1,000 or per order if less than 1,000.										

Please call for an estimate for: full graphics, including heavy coverage, four color process and stocks not listed in product information.

(R)

CUSTOM DESIGN

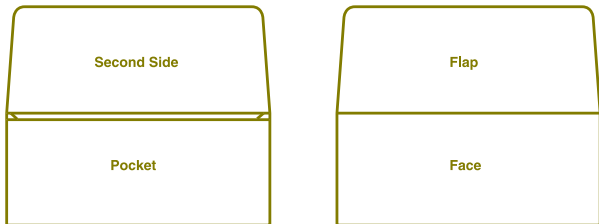

INSIDE VIEW (OPEN)

● Wallet-Style Folders

01-01 4 1/2" x 10 1/4" 02-01 6" x 9 7/8" 02-10 6" x 10 1/2"
 01-02 4" x 9 1/4" 07-01 2 1/2" x 4"

From receipts to important documents, this versatile folder style has a size that fits them all. Features a sealed pocket and wallet-style flap.

Price: See table on page 44.

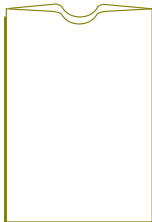

● Pull-Out Style Holders

19-01 2 1/2" x 3 1/2" 19-03 5 3/4" x 8 3/4"
 19-02 5" x 7 1/4" 19-04 6 1/4" x 9"

Documents slide easily into this folder. Perfect for holding report cards, licenses or library cards.

Price: See table on page 44.

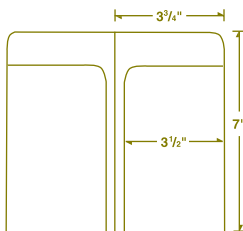

INSIDE VIEW (OPEN)

● Receipt Holder – 04-01 3 3/4" x 7"

Great for bank and financial receipts.

Price: See table on page 44.

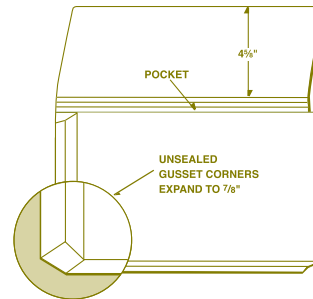

● Wallet-Style Expansion Portfolio

02-11 6" x 9 7/8"

Ideal for large manuals and bulky service information. Item ships flat with gusset out.

Price: See table on page 44.

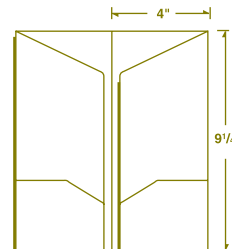

INSIDE VIEW (OPEN)

● Four-Pocket Folder

45-01 4" x 9 1/4"

Perfect for holding travel documents, itineraries, passports and more.

Price: See table on page 44.



● Tuck Tab Document Folder – 01-04 4 1/4" x 9"

Price: See table on page 44.

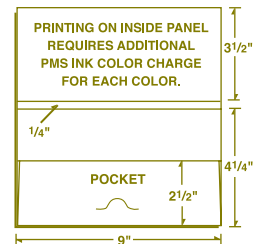

Artwork (Electronic)

We have an electronic workflow and accept all MAC and MAC compatible files. We do not accept films or traditional black & white art. Files need to be set-up per our Preflight Checklist guidelines in acceptable programs (current versions of QuarkXPress, InDesign, Illustrator and PhotoShop). Unacceptable programs include Microsoft Word, Publisher and PowerPoint. Catalog items **MUST** be submitted on our design templates. Preflight Checklist and templates are available at www.admoreonline.com. Send all files being used – include printer & screen fonts and embedded graphics. For verification a hard copy of file output (**color separated lasers or .PDF**) is required along with the electronic file. When utilizing our FTP site or emailing smaller files, be sure to **properly label the transmission with your dealer information so we can match it to your order**. Incorrect files will delay production and charges to correct or alter files will be billed at \$180.00 list (P) per hr.

Artwork (Copy Errors)

All submitted copy is reviewed before production. We pride ourselves on making every effort to ensure accuracy and that your expectations are met. However, we are not liable for errors in designer's files that inadvertently become part of the product. **We are not responsible for unexpected file output if a hard copy (color separated lasers or .PDF) of designer's file is not sent.**

Artwork / Disk / Die Storage

All customer submitted disks are returned after the job has been completed. All foil & emboss dies, custom diecutting dies and archived files are kept for 24 months. At that point, if we have not received a written request for return, materials are recycled without notice.

Changes / Cancellations

Changes to orders in progress may require additional cost and/or time. Cancellation after work has begun will require payment for work performed, materials ordered or generated (including preflight and laser output of electronic files) and any re-stocking fees incurred. A minimum cancellation fee of \$50.00 list (P), is applied once an order has been entered into our system.

Damaged Goods / Claims

In the case of loss or damage in transit, the liability is that of the carrier. **Please mark the shipper "received damaged"**. It is important to inspect all materials upon arrival. Cartons may be opened for inspection, **but the damaged merchandise and containers may not be disposed of**. A claim must be filed with the carrier within **10 days** after receipt of merchandise. Please contact us immediately if you have received damaged merchandise. **All other claims must be made within 30 days of delivery.**

Embossing

Size of emboss area included in base is listed in price tables. This includes one area, single level raised, blind (no ink/foil) emboss. Copy is raised to the maximum lift allowed by the stock and your copy design. Copy needs to be $\frac{1}{8}$ " away from all sides. Please call for an estimate when combining embossing with foil stamping or printing. Multi-level or sculptured effects are available. **EMBOSS ARTWORK NOTE:** Thicker, larger copy is better. Avoid type smaller than 10 pt., screens, very fine lines (no thinner than this ) and copy with tight intricate detail. Submit one color art in the size you want to appear on folder (consider maximizing the allowable square inches found in the price table). Convert type to outlines and send vector (.EPS) art. No RGB, .JPG, .GIF or web images.

Foil Stamping

Size of one foil area included in base is listed in price tables. See inside back cover for standard foil colors. We can order custom and special effect foil colors. Non-metallic and pearized foils will look different when used on dark stocks. Please call for an estimate when combining foil stamping with embossing or printing. **FOIL STAMP ARTWORK NOTE:** Avoid type smaller than 8 pt., screens, halftones, very fine lines and copy with tight intricate detail (spaces closer than this ) which can cause foil to plug. Submit one color art in the size you want to appear on folder (consider maximizing the allowable square inches found in the price table). Convert type to outlines and send vector (.EPS) art. No RGB, .JPG, .GIF or web images.

Lamination

Bonds a strong, protective layer of plastic to the sheet. Most durable of the available coatings. Available in gloss or matte finish. Matte lamination may show scuffing and can alter appearance of print color. See individual product specifications or price tables for additional charges.

Overruns or Underruns

Due to the number of production processes involved in the manufacture of your folder, it is not possible to determine the exact quantity we will complete.

Please indicate your desired quantity using one of the following methods:

STANDARD TRADE PRACTICE - Billed for the exact quantity shipped, not to exceed 10% over or under the quantity ordered.

NO OVERS - Must be indicated on order. Order could run short by more than 10%. Billed for the exact quantity shipped.

EXACT QUANTITY - Add 10% to the price for the special handling involved.

NO UNDERS - Your order may run over by more than 10%. Billed for the exact quantity shipped.

Printing - PMS Colors

Unless specified otherwise, the print base shown in the tables includes one or two PMS ink color(s) in any location on the front and back cover, plus pockets (one side of the sheet). No heavy ink coverage. Orders **MUST** specify a PMS number or a color match charge of \$50.00 list (P) per color will be applied. Choose ink colors that are darker than the stock you select. Inks will appear different on uncoated or non-white stocks. If necessary, we will apply an overall gloss aqueous coating **FREE**. Please call for an estimate when combining printing with embossing or foil stamping. Additional ink and heavy coverage charges are found in the price tables. **PMS PRINTING ARTWORK NOTE:** Define colors as spot and not RGB or CMYK. Send vector (.EPS art) with all type converted to outlines or 1200 dpi .TIF file. No .JPG, .GIF or web images.

Printing - Four Color Process

The four color process print base shown in the tables includes process printing in any location on the front and back covers, plus pockets (one side of the sheet). An overall gloss aqueous coating will be applied **FREE**. If no color proof is submitted or requested, we will run to standard color densities. Do not rely on color monitors for accurate color representation. We output at 175 line screen and recommend the use of white stocks. **PROCESS ARTWORK NOTE:** Process graphics **MUST** be in CMYK and not RGB. We are **not responsible for color shifts** that may occur when PMS or RGB files are converted to CMYK.

Printing - Heavy Ink Coverage

Refers to the increased amounts of ink necessary for a solid block of color 80 sq. inches or larger and full bleeds. We will notify you of the additional charge prior to production. An overall gloss aqueous coating will be applied **FREE**.

Printing - UV Inks

Environmentally friendly UV inks require no solvents or off-set powder like conventional inks. Since the ink is cured (dried) instantly in-line by ultra-violet lamps, total production times are shorter. Especially effective when used with in-line UV coatings. Call for pricing.

Production Time

Average production time is noted for each item. Multiple processes require the most production time. Items requiring special estimates vary in production time. Production days are Monday through Friday, excluding Holidays. **Production time does not begin until all correct artwork components are received.** Orders with accurate files will precede orders improperly set-up or requiring adjustments. Normal production time is required after return of proof.

Proofs

Your first proof is **FREE**. Allow 2-3 working days to send a proof. Changes to proofs, additional proofs and actual press proofs, incur additional charges. Color proofs need to be returned prior to production. Approval or changes need to be indicated in writing. We cannot guarantee color matching to customer supplied proofs. Normal production time is required after proof approval.

Rights To Promote

The plant reserves the right to use all products produced by the plant in the plant's advertising, promotional literature, displays and sample programs unless instructed otherwise in writing by the dealer at the time of the order. In addition, the purchaser agrees to assume any liability resulting from actions or demands brought against the manufacturer for patent or copyright infringements.

Rush Schedules

Schedules can often be adjusted based on the specifics of your order. **Be sure to tell us when you need it.** We frequently ship jobs early, however, if you need us to guarantee an early ship date, extra charges may apply. Expedited methods of shipping are available for an additional charge.

Samples

We carry a large assortment of sample products, available by graphics and industry. Let us know your requirements and we will be happy to send them via ground shipping **FREE** of charge. Additional charges apply for overnight shipping.

Shipping

Freight F.O.B. factories in Michigan and/or California. We normally ship U.P.S. ground delivery inside the continental U.S. For larger shipments, we use more economical motor freight. If you desire air shipment, please advise us and specify your carrier. If none is specified, we'll choose an efficient carrier.

Inside deliveries must be indicated on order.

Split Shipping

We will split shipments to two destinations **FREE** of charge. There is a \$24.00 list (P) charge for each additional destination.

Stocks

Custom stocks are available upon request. Stock selection or manufacturers may change without notice. All stocks are subject to occasional mill variations in texture, weight or color. Not all stocks can be printed on (ColorCoats, MarbleCoats, etc.).

Union Label

Our union label can be added to any imprint upon request for no additional charge. Products are manufactured in the U.S.A.

UV Coating

A very high gloss finish applied to the sheet like a protective varnish. Exposure to ultraviolet light cures the finish to a brilliant shine. Must be applied to an enamel or clay coated paper, such as our Semi-gloss White. Shinier than varnish but does not provide the protection of lamination. Tends to fingerprint on large areas of dark ink (wipes away easily). We also offer Spot UV to highlight certain areas of your copy design rather than the full sheet, call for pricing.

Varnish / Aqueous Coating

A clear finish that seals the ink against smearing or scuffing. Adds no durability to the product. An overall gloss aqueous coating is applied **FREE** of charge. Matte, satin and spot coatings are available for an additional charge.

Great Presentations

Shouldn't Stop With the Folder...

...Introducing **COLORWORX!**

Specializing in economical, four color process printing.

The newest part of The Admore® Line provides the high quality, commercial printing you expect, at a price you can afford. With low minimum quantities and quick turnaround times, **COLORWORX** items are the perfect complement to your other presentation products.

- Sell Sheets
- Rack Cards
- Postcards
- Statement Stuffers
- Brochures
- Door Hangers
- Table Tents
- Greeting & Note Cards
- Posters
- Business Cards
- Book Marks
- Letterhead



Grab your customers' attention, enhance your products and promote your business with help from **COLORWORX!**



DAYLE DESIGNS

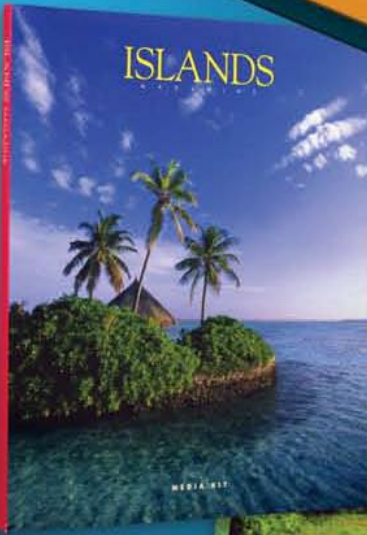

earth
& stone
concepts inc.



Expect More. Get More.

Design and Manufacture of Anything With Ink on It!

www.dayledesigns.biz • dayledesigns@comcast.net
8518 Kimmie St. SW • Olympia, Washington 98512

Phone/Fax **360-352-4051**

**Dayle
Designs**